

This publication has been superseded by INSAG-7

safety series
safety series
No. 75-INSAG-1

INTERNATIONAL NUCLEAR SAFETY ADVISORY GROUP

**Summary Report on the
Post-Accident Review Meeting
on the Chernobyl Accident**



INTERNATIONAL ATOMIC ENERGY AGENCY, VIENNA, 1986

This publication has been superseded by INSAG-7

This publication has been superseded by INSAG-7

**SUMMARY REPORT ON THE
POST-ACCIDENT REVIEW MEETING
ON THE CHERNOBYL ACCIDENT**

Report by the International Nuclear Safety Advisory Group

This publication has been superseded by INSAG-7

The following States are Members of the International Atomic Energy Agency:

AFGHANISTAN	GUATEMALA	PARAGUAY
ALBANIA	HAITI	PERU
ALGERIA	HOLY SEE	PHILIPPINES
ARGENTINA	HUNGARY	POLAND
AUSTRALIA	ICELAND	PORTUGAL
AUSTRIA	INDIA	QATAR
BANGLADESH	INDONESIA	ROMANIA
BELGIUM	IRAN, ISLAMIC REPUBLIC OF	SAUDI ARABIA
BOLIVIA	IRAQ	SENEGAL
BRAZIL	IRELAND	SIERRA LEONE
BULGARIA	ISRAEL	SINGAPORE
BURMA	ITALY	SOUTH AFRICA
BYELORUSSIAN SOVIET SOCIALIST REPUBLIC	JAMAICA	SPAIN
CAMEROON	JAPAN	SRI LANKA
CANADA	JORDAN	SUDAN
CHILE	KENYA	SWEDEN
CHINA	KOREA, REPUBLIC OF	SWITZERLAND
COLOMBIA	KUWAIT	SYRIAN ARAB REPUBLIC
COSTA RICA	LEBANON	THAILAND
COTE D'IVOIRE	LIBERIA	TUNISIA
CUBA	LIBYAN ARAB JAMAHIRIYA	TURKEY
CYPRUS	LIECHTENSTEIN	UGANDA
CZECHOSLOVAKIA	LUXEMBOURG	UKRAINIAN SOVIET SOCIALIST REPUBLIC
DEMOCRATIC KAMPUCHEA	MADAGASCAR	UNION OF SOVIET SOCIALIST REPUBLICS
DEMOCRATIC PEOPLE'S REPUBLIC OF KOREA	MALAYSIA	UNITED ARAB EMIRATES
DENMARK	MALI	UNITED KINGDOM OF GREAT BRITAIN AND NORTHERN IRELAND
DOMINICAN REPUBLIC	MAURITIUS	UNITED REPUBLIC OF TANZANIA
ECUADOR	MEXICO	UNITED STATES OF AMERICA
EGYPT	MONACO	URUGUAY
EL SALVADOR	MONGOLIA	VENEZUELA
ETHIOPIA	MOROCCO	VIET NAM
FINLAND	NAMIBIA	YUGOSLAVIA
FRANCE	NETHERLANDS	ZAIRE
GABON	NEW ZEALAND	ZAMBIA
GERMAN DEMOCRATIC REPUBLIC	NICARAGUA	ZIMBABWE
GERMANY, FEDERAL REPUBLIC OF	NIGER	
GHANA	NIGERIA	
GREECE	NORWAY	
	PAKISTAN	
	PANAMA	

The Agency's Statute was approved on 23 October 1956 by the Conference on the Statute of the IAEA held at United Nations Headquarters, New York; it entered into force on 29 July 1957. The Headquarters of the Agency are situated in Vienna. Its principal objective is "to accelerate and enlarge the contribution of atomic energy to peace, health and prosperity throughout the world".

© IAEA, 1986

Permission to reproduce or translate the information contained in this publication may be obtained by writing to the International Atomic Energy Agency, Wagramerstrasse 5, P.O. Box 100, A-1400 Vienna, Austria.

Printed by the IAEA in Austria
September 1986

This publication has been superseded by INSAG-7

SAFETY SERIES No. 75-INSAG-1

**SUMMMARY REPORT ON THE
POST-ACCIDENT REVIEW MEETING
ON THE CHERNOBYL ACCIDENT**

**Report by the
International Nuclear Safety Advisory Group**

**INTERNATIONAL ATOMIC ENERGY AGENCY
VIENNA, 1986**

This publication has been superseded by INSAG-7

The International Nuclear Safety Advisory Group (INSAG) is an advisory group to the Director General of the International Atomic Energy Agency, whose main functions are:

- (1) To provide a forum for the exchange of information on generic nuclear safety issues of international significance;
- (2) To identify important current nuclear safety issues and to draw conclusions on the basis of results of nuclear safety activities within the IAEA and of other information;
- (3) To give advice on nuclear safety issues in which an exchange of information and/or additional efforts may be required;
- (4) To formulate, where possible, commonly shared safety concepts.

THIS SAFETY SERIES IS ALSO PUBLISHED IN
FRENCH, RUSSIAN AND SPANISH

SUMMARY REPORT ON THE POST-ACCIDENT REVIEW MEETING
ON THE CHERNOBYL ACCIDENT
IAEA, VIENNA, 1986
STI/PUB/740
ISBN 92-0-123186-5

This publication has been superseded by INSAG-7

FOREWORD

by the Director General

One of the main functions of the IAEA is to serve as a forum in which Member States can learn from each other's experience and co-operate in the peaceful uses of nuclear energy. At the time of my visit to Moscow, on 9 May, the USSR expressed its willingness to provide to the Agency information on the Chernobyl accident. On 21 May the Board of Governors decided to convene a meeting of nuclear safety experts to discuss the accident; it also decided that the results of that meeting and recommendations for further IAEA action should be transmitted to the Board before its September meeting to assist IAEA Member States in learning from this accident and thus to further improve nuclear power safety.

The Post-Accident Review Meeting took place in Vienna on 25-29 August 1986 under the chairmanship of the Swiss nuclear scientist Mr. R. Rometsch, a former Deputy Director General of the IAEA.

I requested that INSAG (the International Nuclear Safety Advisory Group) participate in the Post-Accident Review Meeting and prepare a report summarizing the information presented and the discussions at the Meeting and containing INSAG's recommendations for further action.

A large number of experts from Agency Member States and from other international organizations participated in the discussions at the Meeting, receiving from Soviet experts detailed information on the accident and contributing from their own experience to the discussion of specific issues and to the formulation of proposals for follow-up actions. During the week after the Meeting, INSAG and associated experts prepared, as I had requested, this report, with the help of IAEA-nominated experts in the wide range of nuclear safety and radiation protection disciplines involved and of several Soviet experts made available to INSAG.

Intense discussion among the experts during this one-week period led, as stated in the INSAG report, to a clearer picture of the evolution of the accident and its consequences that is reflected in the report. Taking into account proposals put forward during the Meeting in the light of the greater understanding of the accident which was being gained, INSAG has presented in the report its recommendations for further actions.

Some actions require co-operation between the IAEA and other international organizations such as WHO, WMO, FAO and UNSCEAR, and discussions have already been scheduled on how to arrange for such co-operation.

This INSAG report, while not a substitute for the Working Documents prepared by the Soviet experts, synthesizes and integrates the written and oral presentations of the Soviet experts and the discussions among the participants, so that the accident and its consequences can be understood by the technical community and by non-technical decision makers. Thus, the report can serve as an important frame of reference for further consideration of the significance of the Chernobyl accident.

This publication has been superseded by INSAG-7

It provides a solid basis for action that, in my view, need not and should not wait for the further assessments that are to come.

I should like to thank all those who worked so intensively to produce this report: the Chairman and the other members of INSAG, the associated experts of INSAG, the IAEA-nominated experts, the Soviet experts who were made available to INSAG, and the IAEA technical staff and other personnel who provided close support.

Considering how serious the consequences of errors can be in the nuclear field, it is vitally important that we thoroughly investigate and learn from each error. All those who contributed to the Post-Accident Review Meeting on the Chernobyl accident and to the preparation of this report have helped to carry out a searching inquiry and have enabled us all to learn a great deal from the painful experience of Chernobyl, thereby contributing to the enhancement of the safety of nuclear power.

EDITORIAL NOTE

The mention of specific companies or of their products or brand names does not imply any endorsement or recommendation on the part of the IAEA.

CONTENTS

EXECUTIVE SUMMARY.....	1
1. Introduction.....	1
2. The Post-Accident Review Meeting.....	1
3. The INSAG Report.....	2
4. Description of Unit 4 of the Chernobyl nuclear power station.....	2
5. Description of the accident.....	3
6. Early reactions at the power plant site.....	4
7. Radionuclide release.....	5
8. Radionuclide transfer through the environment and exposure of members of the public.....	5
9. Health effects.....	6
10. Emergency measures and decontamination.....	7
11. General observations and conclusions.....	8
INTRODUCTION.....	13
1. Purpose of the Report.....	13
2. Scope of the Report.....	13
3. Preparation of the Report.....	14
Section I: THE ACCIDENT AT CHERNOBYL UNIT 4.....	15
1. Overview of the circumstances of the accident.....	15
2. Description of events.....	17
3. Chronology of events.....	27
4. Main contributing factors.....	28
5. Remedial action.....	30
6. Lessons and recommendations.....	31
Section II: THE RADIONUCLIDE RELEASE FROM THE ACCIDENT...	33
1. Information provided by the Soviet Union on the radionuclide release	33
2. Discussion of release in terms of mechanisms.....	37
3. Retention of released materials.....	39
4. Implications of the Chernobyl radionuclide releases for the technology for estimating severe accident source terms.....	40
5. Recommendations concerning follow-up work and activities involving international co-operation.....	41

Section III: THE RESPONSE AT THE SITE.....	43
1. Fire-fighting.....	44
2. Accident management.....	45
3. Basic assessment of the accident management activities.....	46
4. Radiological site survey.....	47
5. Cleanup of the site.....	49
6. Robotics.....	49
7. Diagnostic instrumentation.....	49
8. Entombment of the damaged unit.....	51
Section IV: RADIATION PROTECTION ASPECTS OF THE ACCIDENT	53
1. Introduction.....	53
2. Initial on-site emergency response.....	53
3. Off-site emergency response.....	54
4. Decontamination.....	57
5. Transport of radionuclides and doses to the public.....	59
6. Health effects.....	62
Section V: SAFETY ISSUES TO BE PURSUED.....	69
Issue No. 1: Assessment of safety procedures.....	69
Issue No. 2: Operational analysis of the accident sequence.....	69
Issue No. 3: Feasibility of containing the consequences of such an accident.....	70
Issue No. 4: Man-machine interface in diagnosing incipient accidents..	70
Issue No. 5: Improving scientific knowledge for evaluating 'source terms'.....	71
Issue No. 6: Accident management on-site.....	71
Issue No. 7: Operational safety experience.....	72
Issue No. 8: On-site decontamination.....	72
Issue No. 9: Models for predicting radioactive dispersion.....	72
Issue No. 10: Radiation protection.....	73
Section VI: GENERAL OBSERVATIONS AND PROVISIONAL CONCLUSIONS.....	75
A. Nuclear safety.....	76
1. <i>No new physical phenomena have been identified</i>	76
2. <i>There is a need for a 'nuclear safety culture' in all operating nuclear power plants</i>	76

This publication has been superseded by INSAG-7

3. <i>The defence in depth concept must really be implemented in reactor design</i>	77
4. <i>The importance of a satisfactory man-machine interface is re-emphasized</i>	77
B. Radiation protection.....	78
1. <i>Early response</i>	78
2. <i>Radionuclide release</i>	79
3. <i>Radionuclide transfer and exposure of members of the public</i>	79
4. <i>Late stochastic health effects</i>	80
5. <i>Decontamination</i>	81
C. Summary conclusions.....	81
Section VII: RECOMMENDATIONS.....	83
A. Nuclear safety.....	83
1. <i>Follow-up activities</i>	83
2. <i>Further IAEA and other international activities</i>	83
B. Radiation protection.....	85
1. <i>Follow-up activities</i>	85
2. <i>Further IAEA and other international activities</i>	85
C. General.....	87
Annex: RBMK REACTORS AT CHERNOBYL NUCLEAR POWER STATION UNITS 3 AND 4.....	89
1. Operating history of RBMK 1000 reactors.....	89
2. General description of the Chernobyl station site and of the design features of RBMK 1000 reactors.....	89
3. Safety systems.....	100
LIST OF PARTICIPANTS.....	105

This publication has been superseded by INSAG-7

EXECUTIVE SUMMARY

1. INTRODUCTION

On 26 April 1986 at 01:23 an accident occurred at the fourth unit of Chernobyl nuclear power station in the Ukraine, Soviet Union, which resulted in the destruction of the reactor core and part of the building in which it was housed. Large amounts of the radioactive materials in the reactor core were released from the building into the surrounding environment. Hot materials expelled in the event started fires which complicated the situation and lifted more radioactive materials high into the air. Courageous action by Soviet response teams starting immediately and acting over the next few days effectively reduced this additional release of radioactive materials. Thirty-one members of the plant operating personnel and the response teams gave their lives to stop the releases and to mitigate the consequences of the accident.

Much of the radioactive material released was carried away in the form of gases and dust particles by normal air currents. Radioactive materials were widely dispersed in this manner, with most remaining in the Soviet Union.

2. THE POST-ACCIDENT REVIEW MEETING

The IAEA and the Soviet Union agreed to hold a Post-Accident Review Meeting in Vienna. This Meeting was held over the period 25–29 August 1986.

At the Meeting, leading Soviet scientists and nuclear engineers presented a report which provided basic technical information on Chernobyl nuclear power station, and an account of the causes of the accident, the accident sequence, and its consequences and the countermeasures taken. Soviet experts also reported on technical, medical and environmental research programmes initiated after the accident. This research should generate new information concerning risks related to nuclear power and the health effects of ionizing radiation.

The frank and open presentation by the Soviet experts was well received by participants. The feeling was general that the results of the Meeting exceeded expectations. Many questions were presented in written form after the Soviet presentations, reflecting the desire to elaborate further details that would be needed to make use of the information.

There was a common understanding on the need to strengthen international co-operation on nuclear safety and radiological protection. It is believed that the discussions that took place may have helped Soviet experts to benefit in their planning of the necessary research programme.

3. THE INSAG REPORT

The International Nuclear Safety Advisory Group (INSAG) was requested by the IAEA Director General "to prepare, on the basis of the information presented and the discussion, a summary report of the Meeting". He also asked that this report be available "for his consideration and transmission to the Board of Governors of the IAEA before its September meeting". The report was also to include INSAG's recommendations for future action.

The main body of this report is derived from the excellent reports presented by the Soviet experts to the Meeting (Working Documents entitled: USSR State Committee on the Utilization of Atomic Energy, The Accident at the Chernobyl Nuclear Power Plant and its Consequences (Information compiled for the IAEA Experts' Meeting, Vienna, 25-29 August 1986), Parts I and II, August 1986) and additional material presented by the Soviet experts during the meeting (Post-Accident Review Meeting Slides, Parts I and II). This material can hardly be condensed further in this Executive Summary; only the main points are given.

The INSAG report contains the summarized results of many helpful discussions in the Working Group sessions between the Soviet experts and invited experts, the IAEA-nominated experts, IAEA staff members, and finally the INSAG members themselves. A clearer understanding has emerged from this process, although some of the reported information is preliminary owing to uncertainties about details which remain at this early date.

It would be surprising indeed if the report, issued after a short period of preparation and at a time when many questions remain to be settled by analysis, were found to be correct in every detail. INSAG therefore had to use its best judgement in forming conclusions and recommendations for action. The main task of the report is to provide these provisional conclusions and recommendations, prepared according to the information available, which is still of a preliminary nature. Nevertheless, the report represents a consensus of INSAG members.

4. DESCRIPTION OF UNIT 4 OF THE CHERNOBYL NUCLEAR POWER STATION

Unit 4 of the Chernobyl nuclear power station, with an operating power of 1000 MW(e), 3200 MW(th), was one of 15 RBMK type reactors brought into operation in the Soviet Union. Four have been operating at Chernobyl, and two more are under construction there. The RBMKs are usually built in pairs, with two units occupying opposite sides of a single building complex. Chernobyl Units 3 and 4 are linked in this way, and they shared some plant systems.

The RBMK reactor is a graphite moderated pressure tube type reactor. It is cooled by circulating light water that boils in the upper parts of vertical pressure

This publication has been superseded by INSAG-7

tubes to produce steam. The steam is produced in two cooling loops, each with 840 fuel channels, two steam separators, four coolant pumps and associated equipment. The steam separators supply steam directly to two 500 MW(e) turbogenerators, each with a condenser and feedwater system. The reactor is refuelled on-load using a special machine.

A major part of the coolant circuits is enclosed in a series of strong containment rooms. These are connected to water filled suppression systems below the reactor to capture and condense steam that might be released in the containment rooms by any leakage of coolant. A notable exception is the upper part of the reactor, especially refuelling end-caps on channels above the core.

At equilibrium fuel irradiation, the RBMK reactor has a positive void reactivity coefficient. However, the fuel temperature coefficient is negative and the net effect of a power change depends upon the power level. Under normal operating conditions the net effect (power coefficient) is negative at full power and becomes positive below approximately 20% of full power. The operation of the reactor below 700 MW(th) is restricted by operating procedures owing to the problems associated with maintaining the thermal-hydraulic parameters in their normal operating range.

The RBMK reactor includes 211 absorbing rods which are used for control of the global and spatial power distribution and for emergency protection. Emergency protection in the RBMK reactor is provided by insertion of all absorbing rods, up to a maximum speed of 0.4 m/s. To ensure the required power distribution, and the effectiveness of the negative reactivity introduction in emergency conditions, it is prescribed in regulations that not fewer than 30 effective rods should remain inserted in the reactor core.

5. DESCRIPTION OF THE ACCIDENT

The accident happened during a test being carried out on a turbogenerator at the time of a normal scheduled shutdown of the reactor. This was intended to test the ability of a turbogenerator, during station blackout, to supply electrical energy for a short period until the standby diesel generators could supply emergency power. Improper written test procedures from the safety point of view and serious violations of basic operating rules put the reactor at low power (200 MW(th)) operation in coolant flow rate and cooling conditions which could not be stabilized by manual control. In view of the particular design characteristics already mentioned (the positive power coefficient at low power levels), the reactor was being operated in an unsafe regime. At the same time, the operators deliberately and in violation of rules withdrew most control and safety rods from the core and switched off some important safety systems.

The subsequent events led to generation of an increasing amount of steam voids in the reactor core, thereby introducing positive reactivity. The beginning of an

This publication has been superseded by INSAG-7

increasingly rapid rise in power was seen, and a manual attempt was made to stop the chain reaction, the automatic trip, which the test would have triggered earlier, having been blocked. However, the possibility of a rapid shutdown of the reactor was limited as almost all the control rods had been withdrawn completely from the core.

The continuous reactivity addition by void formation led to a super-prompt critical excursion. The Soviet experts calculated that the first power peak reached 100 times the nominal power within four seconds.

Energy released in the fuel by the power excursion suddenly ruptured part of the fuel into minute pieces. This burst mechanism is well known from experiments in safety research programmes. Small hot fuel particles (possibly also evaporated fuel) caused a steam explosion.

The energy release shifted the 1000 tonne reactor cover plate and resulted in all cooling channels on both sides of the reactor cover being cut. After two to three seconds a second explosion was heard and hot pieces of the reactor were ejected from the destroyed reactor building. It is still uncertain what role hydrogen may have played in this explosion. The destruction of the reactor permitted the ingress of air which led subsequently to burning of graphite.

6. EARLY REACTIONS AT THE POWER PLANT SITE

The accident caused some hot graphite and fuel to be blown out onto the roofs of nearby parts of the building. Fires began, especially in the hall of Unit 4, on the roof of Unit 3 and on the roof of the machine room housing the turbogenerators of the two reactors. Fire units from the nearby towns of Pripyat and Chernobyl responded promptly and heroically fought the fire, which for a time threatened Unit 3.

The fire was finally extinguished at 05:00 on 26 April, about 3.5 hours after it had started. At the same time, Unit 3, which had continued to operate with essentially no damage, was shut down. Units 1 and 2 were shut down early in the morning of 27 April. All three units still remain shut down, with guardian crews manning them.

Radioactive fission products continued to be evolved from Unit 4 in substantial amounts until after 5 May, about nine days after the accident.

Early in the sequence, the release of fission products was associated with the burning of graphite, which was kept at a high temperature by heat they generated. Large amounts of boron, dolomite, sand, clay and lead were dropped onto the reactor to suppress the release of fission products. In all about 5000 tonnes of material were dropped, including 2400 tonnes of lead. For a time after 1 May, the release of volatile fission products actually increased as the material that had been dropped insulated the core, which then heated up again. But on 5 May the rate of heat loss began to exceed the heatup rate, particularly as the smouldering graphite was quenched.

7. RADIONUCLIDE RELEASE

Destruction of the Chernobyl containment and core structures led to the release of radioactivity from the plant. The Soviet experts estimated that 100% of the noble gas radionuclides escaped the plant. Of the remaining, condensable, radionuclides, the release represented up to about 2×10^{18} Bq (5×10^7 Ci)¹ or about 3-4% of the core inventory of radioactivity. This release comprised about 10-20% of the caesium, iodine and tellurium inventories and about 3-6% of the inventories of other radionuclides.

The release of radionuclides from the Chernobyl plant did not occur as a single acute event. Rather, there was an initial intense release associated with the destructive events in the accident. Release rates fell over the next few days, probably as a result of accident management activities undertaken. Release rates were about 7×10^{16} Bq/d (2×10^6 Ci/d) five days after the accident initiation. At that point, the release rates began to increase and reached about 3×10^{17} Bq/d (8×10^6 Ci/d) about nine days after the accident initiation. There was then a drop in the radionuclide release to 4×10^{13} Bq/d (1×10^3 Ci/d). Release rates have continued to decline since that time.

Further characterizations of the physical and chemical nature of the radionuclide release are being undertaken by Soviet experts. Chemical forms of the material and the particle size distribution of aerosols are being determined. Continued interactions with the Soviet experts as this work progresses will be of value to all reactor safety programmes.

8. RADIONUCLIDE TRANSFER THROUGH THE ENVIRONMENT AND EXPOSURE OF MEMBERS OF THE PUBLIC

This accident differed from those which are usually considered in radiological assessments of hypothetical accident releases from nuclear power plants in that the release was prolonged, it varied in rate and radionuclide composition over time, and the meteorological conditions were complex. These characteristics led to a very complex pattern of atmospheric deposition on the ground, both within the Soviet Union and in other countries. The pattern of deposition was established very quickly through environmental monitoring. Deposited radionuclides, particularly I-131 and caesium isotopes, entered the terrestrial food-chains. Bans on the consumption of various foods were introduced and enforced, and measures were taken in the Soviet Union to provide supplies of uncontaminated drinking water where necessary.

¹ Radioactive releases and activities are corrected to 6 May 1986. All releases and release rates have an uncertainty range of $\pm 50\%$.

This publication has been superseded by INSAG-7

Initial estimates of dose were obtained from environmental monitoring data, supplemented by predictive modelling where necessary. At a later stage direct measurements were made of I-131 in the thyroids of individuals, particularly children, and whole body measurements were carried out to determine levels of Cs-137. These direct measurements enabled better estimates to be made of the doses actually received.

The radionuclide which will contribute most to the collective dose (i.e. the total dose to the population) in the Soviet Union, and to the dose to the whole body of individuals, is Cs-137. The collective dose to the population of the European Soviet Union over the next 50–70 years is estimated to be of the order of 2×10^6 man·Sv, with most individuals receiving a dose over their lifetime which is less than that from natural background radiation. Iodine-131 gave rise to comparatively high doses to the thyroids of some individuals in the short term, but it is not an important contributor to the total dose in the long term either for individuals or for the whole population.

Over the coming months and years these dose estimates will be refined and extended to include doses in other countries as part of international work planned. The vast amount of monitoring data available and still to be obtained in the Soviet Union and elsewhere will provide an invaluable basis for validation and improvement of environmental transfer models, on an international basis.

9. HEALTH EFFECTS

Health consequences of the Chernobyl accident may be divided into two categories: the early non-stochastic and the late stochastic ones. The early effects were limited to the power plant personnel and firemen exposed on the site shortly after the reactor disruption. Of about 300 persons admitted to hospitals, 203 had symptoms of acute radiation syndrome which resulted from whole body gamma irradiation doses from about 2 Gy up to 16 Gy. In addition to being irradiated by penetrating gamma rays, a number of those irradiated with high doses were also exposed to beta emitting radionuclides. In some cases, this beta exposure caused very extensive radiation burns of the skin that were extremely difficult to treat and contributed substantially to the deaths of 29 victims. Technical measures should be taken to prevent the occurrence of extensive skin burns should an accident of a similar nature occur in the future. Internal irradiation proved to be of no real clinical significance in this group. Significant neutron irradiation could also be excluded. No clinical symptoms of acute radiation syndrome were seen in the 135 000 people evacuated from the zone within 30 km of the plant.

The treatment of those with acute radiation syndrome was based mostly on substitutive and supportive measures and on intensive combating of infections. It appears relatively effective within the limitations imposed by the range of doses

This publication has been superseded by INSAG-7

incurred. Bone marrow transplantation for 13 patients who were irradiated with particularly high doses did not appear to offer therapeutic advantages. The experience gained in treatment of the syndrome should be made widely available. It appears that centralized direction of the medical handling of the accident's consequences proved to be advantageous.

The magnitude of the health impact of the late stochastic effects, mostly neoplastic and genetic in nature, can be assessed only after evaluation of the resulting collective doses. The information in this regard from the Soviet Union is preliminary and tentative. From the information available it appears that over the next 70 years, among the 135 000 evacuees, the spontaneous incidence of all cancers would not be likely to be increased by more than about 0.6%. The corresponding figure for the remaining population in most regions of the European part of the Soviet Union is not expected to exceed 0.15% but is likely to be lower, of the order of 0.03%. The relative increase in the mortality due to thyroid cancer could reach 1%.

The number of cases of impairment of health due to genetic effects may be judged not to exceed 20–40% of the excess cancer cases. There is no information at present on which possible consequences of the in utero irradiation of human foetuses within the 30 km zone could be assessed. Data on collective doses in other countries are in the process of evaluation, and the assessment of possible stochastic consequences must be deferred to a time when these data become available.

10. EMERGENCY MEASURES AND DECONTAMINATION

Immediately after the alert reached Moscow, a specialist team was dispatched to the site to assist local authorities and plant management. A centralized emergency centre with all authority and powers to direct the response organization was established.

Meteorological and radiological monitoring with the help of airplanes and helicopters were organized and medical aid teams were alerted. Depending on the development of the environmental contamination with time, emergency response measures such as keeping people indoors, iodine prophylaxis and evacuation were carried out.

An enormous set of problems arose in connection with evacuating and relocating people and cattle, monitoring medical and social assistance, and transportation and logistics. Of the site and rescue personnel, about 300 people had to be hospitalized for radiation injuries and burns during the first two days. None of the 135 000 people evacuated from the zone of about 30 km around the plant had to be hospitalized as a result of radiation injuries.

An overall conclusion to be drawn from the emergency response is that, although it had to be initiated at the local level, the actual management of the total emergency situation and response required a rapid acceleration of resource commit-

This publication has been superseded by INSAG-7

ment. Owing to the scale of the accident, such resources and the authority for their commitment could not be expected to exist at the local level. It must be recognized that for any accident of this severity, irrespective of the location or country of occurrence, there would need to be a major commitment of manpower and equipment resources in order to regain control of the situation and to reduce the consequences for the population and environment.

The highly contaminated Units 1, 2 and 3 could be effectively decontaminated by various means to an acceptable level for those personnel who have to keep the plants in a safe shutdown condition.

The scale of the contamination of the plant site and the surrounding area is unprecedented. Problems which will be encountered in the attempt to decontaminate these areas are the safe disposal of large amounts of contaminated earth; the removal of a layer of earth and the associated control of doses to the workers; the fixation of radionuclides in the soil; and finding methods to decontaminate forests and water bodies.

Experience in this field is of great importance and international exchange of experience is very much desired.

11. GENERAL OBSERVATIONS AND CONCLUSIONS

- (1) During this Meeting the Soviet experts explained specific modifications to the RBMK type reactor. These are intended, in combination with improved administrative procedures, to make it much more difficult to reach operating conditions that could result in a fast reactivity excursion from any cause, including severe violation of operating procedures. The brief study reported here cannot provide full confirmation that the intent has been achieved by these modifications. However, INSAG strongly endorses this goal which has been adopted by the Soviet authorities for the RBMK system.
- (2) In a very general way, INSAG concludes that a major event in the class of events termed core disruptive accidents (CDAs) occurred at Chernobyl. An opportunity now exists for the world's safety experts to learn from this tragic event in order greatly to improve our understanding of nuclear safety. This accident is almost a 'worst case' in terms of the risks of nuclear energy.
- (3) The multiple barrier principle and the defence in depth concept are important elements in the philosophy of nuclear reactor safety. In this philosophy, for any component failure at least two barriers must remain to protect the environment from the accidental release of radioactive materials from the reactor core. It is the task of safety system designers to ensure in general the functional independence of each of the different barriers in the event of an accident. Within the defence in depth concept in modern reactors, manual actions of operators are overruled by the automatic safety system when the safety of the plant is seriously threatened.

The automatic protection system for the RBMK reactors was designed many years ago, and more confidence was placed at that time in proper operator action than in automatic safety circuits, assumed to be less reliable. As was noted, RBMK designers had added many safety improvements in past years as a result of operating experience and the review of accidents such as that at Three Mile Island. Nevertheless, heavy reliance on proper operator action still remained.

The effectiveness of the barrier concept in preventing high releases of fission products after an accident has been proved in several cases, including the Three Mile Island accident. The barrier concept in particular has to be enhanced by inherently safe characteristics of nuclear power plant design. In the reactor design, reactivity transients leading to fast power surges have to be terminated immediately and automatically by independent, diverse and testable shutdown mechanisms before severe damage occurs to any reactor system. This stems from the fact that a fast power surge as happened at the Chernobyl plant can endanger all the barriers designed to prevent large releases of fission products after an accident.

- (4) There have been at least three accidents involving power excursions in reactors prior to Chernobyl: NRX, EBR-1 and SL-1.² Many deliberate experiments and extensive analyses of fast reactivity transients have been conducted. The database for accidents of this type is extensive. The general conclusion is that such types of accidents must be prevented to a high degree of reliability because of their potential for destruction of all natural and engineered barriers designed to prevent large releases of fission products. As noted in the previous point, reactivity transients leading to fast power surges must be terminated immediately and automatically by the safety features of the design.
- (5) As described by the Soviet experts and discussed in detail among the experts, the accident was caused by a remarkable range of human errors and violations of operating rules in combination with specific reactor features which compounded and amplified the effects of the errors and led to the reactivity excursion.

A vital conclusion drawn from this behaviour is the importance of placing complete authority and responsibility for the safety of the plant on a senior member of the operations staff of the plant. Of equal importance, formal procedures must be properly reviewed and approved and must be supplemented by the creation and maintenance of a 'nuclear safety culture'. This is a reinforcement process which should be used in conjunction with the necessary disciplinary measures.

² NRX is a heavy water moderated, heavy water cooled experimental reactor which was extensively damaged in a power excursion in 1952. EBR-1 was a sodium cooled fast reactor destroyed during a fast reactivity excursion in 1952. SL-1 was an experimental light water reactor destroyed in 1962 by a power excursion when an operator withdrew a control rod too far.

- (6) As in other technical processes the purpose of automatic control in modern nuclear power plants is twofold:
- To relieve the personnel (operators) from routine work;
 - To assist the personnel in complicated control situations.

In order to meet nuclear safety requirements, two main control levels are used: the operational and the safety control level. The latter is the watchdog for all situations where processes in the plant begin to go outside the operational envelope. The countermeasures taken by the safety systems range from set-back of power production to the fast shutdown of the reactor. By these means the plant would be brought to a safe condition in any eventuality. However, practical experience with nuclear power plant has shown that operational controls have greater relevance to safety than originally expected, and it may be that reliance on correct action is greater than it should be. As a result, the tendency is to design more reliable operational control circuits (for example, by means of redundant systems or improved power supplies), and to improve or extend the set-back controls. Thus, the growth of automatic plant control is born of operational experience.

From the point of view of safety, assistance to the operator is the primary question. There is no doubt that a complex situation can be handled much more easily and reliably by an automatic system. Certainly the designers of that system have much more time to consider all process variants than the operator has in an actual situation. However, what is important in automated systems is to provide means of informing the operator, showing him the status of the plant and its response to his actions. This will allow him to initiate safety steps manually in case of a failure of an automated system.

- (7) In the course of the accident, starting with the fast power surge immediately after 01:23:40 on the morning of 26 April, there was a succession of very complex physical and chemical phenomena in the reactor vault. Many of these phenomena, such as fuel fragmentation, steam explosion and graphite fire, have already been described and analysed. Before the Chernobyl event actual experience of disruptive phenomena of this type was limited to a very small scale, so that severe accident analyses were rather theoretical. Now that a large severe accident has occurred, great benefits can be obtained by the Soviet experts and others in analysing the detailed sequence for possible use in design and licensing decisions.
- (8) The evacuation process after the Chernobyl accident revealed a number of problems in procedures, logistics and administrative actions. In addition, technical and medical problems were unprecedented. The lessons learned from the accident will be very useful in organizing and co-ordinating emergency operations, particularly emergencies with major radiological consequences.

This publication has been superseded by INSAG-7

- (9) With regard to decontamination and accident recovery work performed at Chernobyl, the scope and scale of the effort were far beyond those ever before experienced at a nuclear power plant site. It is observed that all other people who are responsible for this type of work should study this case and learn from it.
- (10) Fighting fires in a nuclear power plant with an added large scale radiological hazard was an entirely new experience. The types of procedures, equipment and protective clothing used in this event should be examined carefully by all those responsible for such emergency responses.
- (11) Medical treatment of acute radiation syndrome was effective within the limits imposed by the doses incurred. Severe skin burns induced by beta radiation added significantly to the difficulties of supportive and substantive treatment of the syndrome, and also affected to a significant degree the fatal outcome of the sickness in 29 victims. Technical measures should be taken to prevent the occurrence of extensive skin burns should an accident of a similar nature occur in the future. Bone marrow transplants performed in selected cases did not appear to offer real therapeutic advantages in this group. Internal contamination was inconsequential in the induction of acute radiation sickness. All this experience should be fully used by the medical community.
- (12) Preliminary estimates have been made of the doses to individual members of the public in the Soviet Union and of the dose to the population as a whole. These estimates will be refined as more data become available, and the overall radiological consequences of the accident will be assessed by UNSCEAR, in co-operation with the IAEA and WHO, on the basis of data collected from member states. International discussions should be held about the methodology for an epidemiological study of workers and selected groups of the population in the region of the plant.

On the basis of these observations and conclusions, INSAG is providing to the IAEA Director General its recommendations for further actions.

This publication has been superseded by INSAG-7

INTRODUCTION

1. PURPOSE OF THE REPORT

A severe accident, the most serious ever at a nuclear power plant, occurred at the fourth unit of the Chernobyl nuclear power station in the Ukraine, Soviet Union, on 26 April 1986. The major release of radioactivity that resulted brought the realization that an event considered to have an extremely low probability had become a reality. The IAEA and the Soviet Union agreed to hold a Post-Accident Review Meeting in Vienna. This meeting was held over the period 25–29 August 1986. More than 500 highly qualified experts from 62 countries and 21 international organizations heard the report of the Soviet experts and participated in the frank and very productive discussions.

The International Nuclear Safety Advisory Group (INSAG) was requested by the IAEA Director General “to prepare, on the basis of the information presented and the discussion, a summary report of the meeting”. He also asked that this report be available “for his consideration and transmission to the Board of Governors of the IAEA before its September meeting”. The report was also to include INSAG’s recommendations for future action.

2. SCOPE OF THE REPORT

The Post-Accident Review Meeting discussed the factors that contributed to the accident and its widespread consequences. Owing to the complex nature of the accident and the extent of its consequences, it will take a long time for a complete and comprehensive assessment of the impacts of the accident to be made by Soviet and other international experts. This report reflects the information available at the Chernobyl Post-Accident Review Meeting.

An Executive Summary gives an overview of the accident, how it happened and its consequences, and INSAG’s general observations and conclusions.

Sections I–IV of the main report present the understanding of INSAG members of the causes of the accident, its evolution and its consequences, the recovery actions and the radiological emergency measures, the nature of the health effects, and the measures taken to limit the consequences. These descriptions are based on the Soviet reports and on the discussions at the Meeting.

Safety issues to be pursued are considered in Section V. In Section VI, INSAG presents its observations and conclusions based on the lessons learned so far from the accident. Section VII provides INSAG’s recommendations, ranging from reactor operation to radiation protection and international co-operation in nuclear safety.

This publication has been superseded by INSAG-7

Finally, the report has a technical annex providing information on the operating history of RBMK reactors and background information on the Chernobyl Unit 4 reactor necessary for understanding other parts of the report.

3. PREPARATION OF THE REPORT

INSAG had general responsibility for preparing the report. It was assisted by a group of experts selected by the IAEA in consultation with the INSAG Chairman. These experts prepared the technical parts of the report, which were then reviewed by INSAG. In addition, Soviet experts were available for clarification and discussions. Staff of the Nuclear Safety Division also assisted INSAG and the other experts in the preparation of these technical documents.

In preparing the report INSAG had available to it information provided by the Soviet experts, namely:

- (a) The Working Documents distributed by the Soviet Union for the Post-Accident Review Meeting³;
- (b) The additional information provided by the Soviet experts in their presentations and in the Working Group discussions during the Meeting.

The overall responsibility for this report lies with INSAG, which expresses its appreciation for the close co-operation of the Soviet experts, the technical assistance of the IAEA-nominated experts and the efficient support of IAEA staff members. Their effective and creative co-operation made it possible to prepare this report within such a short time.

³ USSR State Committee on the Utilization of Atomic Energy, The Accident at the Chernobyl Nuclear Power Plant and its Consequences (Information compiled for the IAEA Experts' Meeting, Vienna, 25-29 August 1986), Parts I and II, August 1986.

Section I

THE ACCIDENT AT CHERNOBYL UNIT 4

1. OVERVIEW OF THE CIRCUMSTANCES OF THE ACCIDENT

This overview subsection is for the more general reader. It is self-contained, and covers similar ground to Subsection 2, though in a different context, and tries to give the non-specialist an impression of the extent of the study carried out by the IAEA-nominated experts. Subsection 2, Description of Events, deals with the technical issues in considerable detail.

Chernobyl Unit 4 operated very successfully for three years, with more than 100 years of operation for this reactor type. Chernobyl Unit 4 was in fact the most successful RBMK unit. The intent on 25–26 April 1986 was to carry out a special electrical systems test just before the plant was shut down for routine overhaul.

The purpose of this was to demonstrate improvements in the capacity of the turbine generators to support essential systems during a major station blackout. This was to be done by cutting steam supplies to one of the turbine generators and testing the capacity for supply at correct voltage during its inertial rundown using main coolant flow pumps as the load. The initiative for the test and the provision of the procedures thus lay with electrotechnical rather than nuclear experts.

The presumption that this was an electrotechnical test with no effect on reactor safety seems to have minimized the attention given to it in safety terms. It was stated that the procedures were poorly prepared in respect of safety, and that authority to proceed was given to the station staff without the necessary formal approval by the station safety technology group. However, as will be clear from what follows, the accident would not have occurred but for a wide range of other interrelated events.

After delays initiated by the system dispatcher, the further conditioning of the plant for the test recommenced late on the night of 25 April, involving a reduction of power towards the test target level of 700–1000 MW(th). This proved difficult because of the mishandling of the control system by the operator. As a result reactor output fell to too low a level.

Power was increased again. The level of 200 MW(th) was achieved with some difficulty and it required many of the control rods to be withdrawn. Note that continuous operation below 700 MW(th) is forbidden by normal safety procedures owing to problems of thermal-hydraulic instability. Two additional main circulation pumps were switched on with the motive of ensuring that the reactor could continue to operate after the test with the necessary number of pumps available. The high flow created by these extra pumps was a violation of normal station procedures since it exceeded approved levels both for the reactor core and for certain individual pumps; more importantly, it made control of the main coolant systems difficult.

This publication has been superseded by INSAG-7

One important consequence was that the operators disabled the reactor trip on separation drum level and steam pressure to ensure that the fluctuations did not cause such a reactor trip and stop the test, again a serious violation of normal station procedure.

In seeking to achieve stability, the operator manoeuvred the feedwater supply and control rods and eventually started the test by cutting the steam flow to the turbine.

Just before this the computer system for centralized monitoring provided the operator with information about the condition of the reactor, including the position of all the control rods at the time. This gave a clear warning, for it showed that the reserve of control rod capacity required to guard against emergency was no longer available. The reactor should have been shut down instantly. However, the operator began the electrotechnical test although the condition of the plant was extremely unstable, as is self-evident, and as will be touched on later.

On starting the test, the turbine generator began to run down. Note here the crucial violation of procedure. The reactor trip on loss of both turbine generators had been disabled previously so that the reactor could remain at power to repeat the test if necessary. It is worth making clear that the test could have, and should have, been conducted in such a way that the reactor tripped when the test began.

Cessation of steam flow to the turbine and its effect on feedwater flow, steam pressure and main coolant flow perturbed the system and introduced rapid void formation in a large part of the core. This led to a rapid increase in the power of the reactor which the emergency shutdown arrangements could not cope with. This increase was caused through the dominance of the positive void coefficient of reactivity (as explained in the following paragraph), which is an important feature of RBMK reactor operation at low power and with the core configuration achieved. The increase in power level caused by the reactivity excursion led in its own right to very rapid steam generation. It also led, it is judged, to overheating and fragmentation of the fuel, which, in contact with the coolant, also caused violent generation of steam. The explosive effects of this process led to the total disruption of the reactor core and associated structures.

The core was so sensitive at the time of the test because the complex manipulation of the plant to maintain the power level ensured that the positive void coefficient of reactivity played a dominant role. This was determined by the feedwater flow changes which minimized the voidage in the coolant, the removal of many control rods from the core and the fact of low power operation, all of which increased the contribution of the void coefficient to the parameter that governs overall stability (the power coefficient: this is the parameter which, if not compensated for, may provide a dangerous amplification of any small power perturbation). It should be stated clearly that in the RBMK reactor this effect is not important in normal operation when the power is high and the configuration of control rods is standard.

This publication has been superseded by INSAG-7

These factors, which influenced adversely the void coefficient in the Chernobyl accident, had additional adverse effects, since the control rod configuration became disturbed and the subcooling of the main coolant diminished. The important factor, however, was the dominance of the void coefficient as a factor in the power coefficient under these abnormal conditions.

The errors and violations of procedures were the major factors contributing to the accident. It seems to have been determined that conducting the test was essential. This led directly to maintaining the reactor on load during the test, continued operation at 200 MW(th), control difficulties caused by switching in the extra pumps, disabling of reactor trips and the ignoring of the reactivity margin display. This series of wilful violations of procedure, extraordinary as they were, in combination with specific characteristics of the RBMK reactor design at low power, led to the disaster.

2. DESCRIPTION OF EVENTS

This subsection describes these same events in detailed narrative form; Table I relates highlights to the time-scale. The purpose is to provide more technical detail for the specialist, so the reader should not be surprised at the duplication of the material of Subsection 1.

The sequence of events given in this subsection is derived from the actual data from the reactor, from very helpful discussion with the Soviet experts and from the mathematical modelling, the results of which were provided by them.

In order to understand the events that led to the accident at Chernobyl Unit 4, it is useful first to identify certain important events during the days of 25 and 26 April. A special test was planned just prior to taking the Unit out of service for scheduled maintenance. The purpose of the test was to demonstrate that a new voltage regulating system on the generator could supply enough power to operate the fast acting emergency core cooling system (ECCS) pump for 40–50 s from turbogenerator inertia during rundown following closure of the turbine emergency stop valve. Previous tests had failed to demonstrate this because the voltage dropped off too rapidly with turbine rundown.

The electrical load of the ECCS pump was to be simulated by powering a greater number of main circulating pumps than are normally supplied by the turbogenerator. The test was intended as a purely electrotechnical one which was thought to have no impact on nuclear safety. As a result, the initiative and direction of the test were left to electrical experts. Little emphasis was put on nuclear safety, and proper authorizations were not obtained. The scene was thus set, but, as will be clear from what follows, the accident would not have occurred without a wide range of other interrelated problems and major violations.

TABLE I. ACCIDENT EVENT SEQUENCE

Time	Event	Interpretation	
		Result of event	Significance
25 April 01:00:00	The start of reactor power ^a reduction	Initial steps of test programme and planned maintenance outage	The slow reduction in power would help to reduce the effects of the buildup of xenon poison
13:05:00	Reactor power reduction stopped ^b at 50% of full power. Turbogenerator No. 7 switched off. Electric power requirements for Unit's needs switched to TG No. 8 (four main circulating pumps, two feed pumps, plus other equipment)		These components will run down with the TG during the test. Pump configuration at this time: four running from TG No. 8; two running from grid; two on standby connected to grid
14:00:00	The ECCS was isolated ^c	Done in accordance with the test plan because crew wished to avoid spurious triggering	Safety principle violation, but blocked ECCS played no role in transient to point of core disruption. Might have been useful in the post-disruption period Note: Discussion by Soviet experts confirmed during the Meeting that ECCS blocking was not necessary for the test
	Load dispatcher halted the ^d power reduction		The long hold in power would further reduce the buildup rate of xenon at test power level

ECCS remained isolated^c

This publication has been superseded by INSAG-7

23:10:00	Power decrease continued towards the target level of 700-1000 MW(th)		In accordance with test procedure. This level was chosen to be above the minimum allowable operating power of the reactor (~ 700 MW(th))
26 April 00:28:00	<i>Operator error with transfer^g from local (LAR) to global power (AR) control — hold power at required level not entered</i>	<i>Power reduced to 30 MW(th) owing to inability of the automatic control rods and lack of prompt operator action to compensate for the void due to powerflow mismatch</i>	Negative reactivity added to system and more manual rods withdrawn to compensate
01:00:00	The reactor was stabilized at ^h a power of 200 MW(th)	<i>Reactor operating below the minimum permissible power level Required reactivity reserve margin violated</i>	No excess reactivity available to raise power
01:03	The fourth main cooling pump ⁱ powered from the grid was connected to the left loop of the heat transport system	Owing to low power and increased flow rate of coolant in the heat transport system, the coolant temperature approached saturation	This adds negative reactivity to the system, necessitating withdrawal of more rods to compensate
01:07	The fourth main cooling pump ^j powered from the grid was connected to the right loop of the heat transport system	<i>The flow rate in some of the main cooling pumps exceeded the permissible value</i> There were significant deviations of the water level and steam pressure in the steam drums	Violation of flow vibration limits based on potential cavitation problems. Addition of both pumps caused further control rod withdrawal and further decrease in reactivity reserve margin
01:19:00	Operator increased feedwater ^k flow. About this time <i>operator blocked the shutdown signals associated with steam drum level and pressure</i>	Core subcooling increase results in more void collapse. Control difficulties throughout this period	

TABLE I. (cont.)

Time	Event	Interpretation	
		Result of event	Significance
01:19:30	Onset of rise in water level in steam drum. The feedwater flow exceeded three times balanced value	The feedwater entering the system exceeds the steaming rate. The cooler water reached the core and reduced the steam quality and core void	Steam drum level increases
	The automatic control rods went ^l up to the upper tie plate		Calculated core average void is now zero
	<i>The manual control rods were^m raised</i>		Addition of negative reactivity compensated by rod withdrawal
01:19:58	The onset of SD steam pressure drop The steam bypass valve was ⁿ closed	Slowdown in the rate of drop of the steam pressure	
01:21:50	<i>The feedwater flow exceeded four times the balanced flow rate</i> <i>Operator abruptly decreases the^o feedwater flow</i>	Steam drum level still rising, pressure still falling	Control rod position constant as modelled. Reduction in pressure produces enough void to compensate additional feedwater flow
01:22:10	Steam quality starts rising ^p , automatic control rods start driving in, water level in steam drum stabilizes	Warmer water reaching core inlet produces a rise in average core void, control rods drive in to compensate	

This publication has been superseded by INSAG-7

01:22:30	Feedwater flow reduced to two-thirds of the balanced flow rate	Operator unable to stop feedwater flow rate at desired level owing to coarseness of control system, not designed for this operating regime	Control rods have moved in to compensate added reactivity of increased voiding
	The distribution of power ^q density and the positions of every control rod were printed out	This was done to establish the flux distribution and reactivity margin prior to beginning the test	<i>Confirmation that the operational reactivity reserve margin was half of the minimum permissible, and the operator should have initiated immediate shutdown based on the computer printout</i>
01:22:45	Feedwater flow rate stabilized	Steam quality in the core stabilizing, pressure starts rising	
01:23:04	<i>The personnel blocked the^r two-TG trip signal</i> Emergency stop valve to the ^s turbine was closed The reactor continues operating at a power of 200 MW(th)	TG No. 8 test starts	<i>Removal of last process safety system trip to allow test to be repeated. This trip would have saved the reactor. Operator aware he was inducing transient which required shutdown. (This was not provided for in the test programme)</i>
01:23:10	One group of automatic control rods starts driving out	Core void decreasing because of increasing system pressure	
01:23:21	<i>Two groups of automatic control rods begin reinsertion</i>	Reduction of the coolant flow rate and the approach of the warmer water to the core	Both of these results lead to positive reactivity addition to the core. Control rods trying to balance this addition
01:23:31	Net reactivity increasing ^t with subsequent slow increase in reactor power	Control rods can no longer balance added reactivity	Power slowly rises; positive power coefficient accelerates reactivity imbalance

TABLE I. (cont.)

Time	Event	Interpretation	
		Result of event	Significance
01:23:40	<i>Operator pushes AZ-5 button (reactor trip)</i>	No apparent effect	
01:23:43	The triggering of the high power and short period alarms The sharp growth of the calculated fuel temperature		<i>The emergency protection is not efficient enough to prevent the reactor runaway</i> Heat transfer crisis
01:23:44	Rapid increase in power		Calculated power reaches 100 times full power

The planned basic steps in the test were: reduction of power to between 700 and 1000 MW(th); blocking the ECCS to prevent spurious initiation during the test; reconfiguration of the main circulating pumps such that four were fed from the station electrical service and four from the turbogenerator; and finally, isolation of the turbogenerator.

At 01:00 on 25 April, preparation for the test was begun^a by the start of power reduction.⁴ At 13:05 the reactor power reached 50% and turbogenerator No. 7 was shut down^b. Shortly afterwards (14:00) the ECCS was isolated^c. The power reduction was stopped on request from system control^d and not resumed until approximately 9 h later.

During this period the ECCS remained isolated^e. Although subsequent events were not greatly affected by this, the fact that the ECCS was not reset reflects the attitude of the operating staff with regard to the violation of normal procedures. At 23:00 power reduction resumed^f and another unusual event occurred. As the operator transferred unit power control from the local to the global regulating system a 'hold power' request was not entered. Consequently the reactor power decreased rapidly^g below the minimum permissible level of 700 MW(th). As a consequence, the power level fell rapidly, being driven by the collapse in voids (reduced boiling) in the reactor. The reactor power fell to 30 MW(th) and the operator was only able to bring it back to 200 MW(th) by manually withdrawing the control rods.

In the power regime below about 700 MW(th), the relationship between steam volume and mass is highly non-linear, to the point where small power (and hence steam mass) changes lead to large steam volume (and hence void) changes, making power control and feedwater control very difficult. The combination of too many control rods withdrawn from the core and operation at this low power level violated a number of procedures. It also created the conditions which both accelerated the reactor's response characteristics to plant or reactor perturbations and reduced the effectiveness of the protection system.

The positions of control rods are of dominant importance in determining these response characteristics. The further they are withdrawn, e.g. to maintain a constant power, the more positive the void coefficient and the more sensitive the reactor to any effect that results in a change in the void distribution and/or level in the core. If the power changes, the heating up of the fuel and the conduction of that heat into the coolant modifies the rate of power rise. The fuel temperature coefficient is negative and the net effect of the fuel temperature rise and the additional voiding resulting from that rise is dependent upon the power level. For the RBMK reactor under normal conditions, the net effect (expressed through the power coefficient) is negative at full power and becomes positive below about 20% power. If operational manoeuvres make the void coefficient larger than normal, this has a direct effect on

⁴ Superscripts refer to the sequence in Table I.

This publication has been superseded by INSAG-7

the magnitude of the power coefficient and the power range over which it remains positive.

The reactor was then operating at 200 MW(th), a level which is forbidden for continuous operation. Nevertheless, the operator decided to continue the test programme. While this was a major violation of operating procedure, it was not in itself enough to have caused the accident. Later actions compounded the problem.

The operator turned on the fourth pump in each loop, according to planⁱ, but, because the reactor was in such a low void condition with low system thermal-hydraulic resistance, the pumps delivered excessive flow to the point where they exceeded their allowed limits derived from cavitation considerations. The throttling valves could not be trimmed further, and the increased core flow led to problems with the level in the steam drum. The operator compensated by increasing the feedwater flow but was unable to get the steam drum level to the desired value because of the coarseness of feedwater control at these power levels.

By 01:19 on 26 April the steam drum level was still hovering near the emergency level. The operator increased feedwater flow^k. Introduction of this feedwater, while raising the drum level, resulted in void reduction which added negative reactivity to the system. The automatic control rods attempted to compensate^l but required further withdrawal of manual rods to maintain the reactivity balance^m. The system pressure started falling, and steam to the turbine bypass was shut off in an attempt to stabilize pressureⁿ. The relationships between pressure, water flow and voidage are all interlinked, so that they determine the control system actions. The system response to these interactions is further sensitized by the low power condition. Since the operators were having trouble with pressure and level control, they switched off the reactor trips associated with these parameters^k.

It should be noted that from around this point onward (01:19 on 26 April), much of the information presented is based on calculations provided by the Soviet experts.

When the operator decided that the steam drum level was sufficiently high he sharply reduced the feedwater flow^o, producing more voidage and more positive reactivity, and the control rods were inserted automatically to compensate and maintain reactor power constant^p. The operator obtained a printout of the neutron flux distribution from the station monitoring computer before the test. This printout showed that too many control rods were out of the core and that he did not have enough reactivity reserve to meet his shutdown requirement^q. At this point he should have shut down the reactor.

The reactor trip on loss of the second generator was switched off to allow a repeat of the test if needed^r. This was a key violation of the test programme, since the reactor would have safely shut down when the test began, even with the rod configuration existing at the time. The test could have, and should have, been conducted in such a way that the reactor tripped when the test began. Such a procedure had

This publication has been superseded by INSAG-7

worked successfully on previous tests. The only reactor protection signals left in operation at this time were the trips of high power and low period.

When the emergency stop valve to the turbine was closed^s, the steam pressure began to rise. The flow through the core started to drop because four of the main cooling pumps were running down with the generator. Increasing pressure, reduced feedwater flow and reduced flow through the reactor are competing factors which determine the volumetric steam quality and hence the power of the reactor. It should be emphasized that the reactor was then in such a state that small changes in power would have led to much larger changes in steam void, with consequent power increases. *The combination of these factors ultimately led to a power increase beginning at about 01:23:30^t.*

The shift foreman ordered shutdown of the reactor at 01:23:40, but by that time it was too late. There was insufficient reactivity left in the rods that were in the core, and the others at the top of the core could not be inserted fast enough to counteract the power increase caused by the competing factors cited. The power is calculated to have reached more than 530 MW within three seconds and the period of the excursion was much less than 20 s. Automatic shutdown initiation on the high power and short period trip signals at this time was too late to be effective. The positive void coefficient of reactivity inherent in the RBMK design continued to add more reactivity and the prompt critical value was exceeded. The power was calculated to have reached 100 times full power within four seconds after 01:23:40. This catastrophic increase in reactor power resulted in fuel fragmentation, rapid generation of steam and ultimate destruction of the reactor core and associated structures.

The rapid damage progression during the first seconds of the accident, the high radiation level and the high temperatures at the later stage precluded direct measurements. The following description of the events is based on visual observations, radiation level measurements, knowledge from experiments before the accident and calculations after the accident. Further analytical and experimental studies as well as analysis of damaged material are necessary to give more insight into the accident sequence and related processes.

The following facts are known:

- An explosion occurred with some material ejected;
- A second explosion occurred with fuel and graphite ejected;
- Graphite blocks were found outside the reactor building;
- Fuel fragments were found outside the building;
- The buildings were severely damaged;
- The crane and refuelling machine collapsed;
- The upper plate was relocated in an upright position within the reactor well;
- All channels were ruptured;
- The chain reaction stopped.

This publication has been superseded by INSAG-7

These observations are linked in the following account. The large reactivity input resulted in an extreme energy addition to the fuel. In such a case the hot fuel and other fragments would have interacted with the surrounding water. The subsequent steam production resulted in a pressure increase. The overpressure and the heat production ruptured a number of fuel channels and the upper part of those channels. During this first explosion fragmented material was ejected and the roof of the reactor hall was damaged. The reactor space, which is designed for the rupture of only one fuel channel, overpressurized and the upper plate with a weight of about 1000 tonnes was lifted.

At this moment all fuel channels were ruptured, the control rods lifted and the horizontal pipes sheared off. The second explosion happened about two to three seconds after the first explosion. It is not yet clear whether the hydrogen produced, reacting with air, was the cause, or whether it was the result of a second power excursion. About 25% of the graphite blocks and material from the fuel channels were ejected. The inventory of the system was blown into the reactor core, the reactor hall and the space below the core. The water-containing shielding tanks broke.

The operators succeeded in injecting water by using the auxiliary feedwater pumps. The injection locations were the steam separators and the headers between the steam separators and the pumps. For about half a day, water was injected at a flow rate of 200–300 tonnes/h. Water was taken from the storage tank for injection into the intact half of the reactor via the ECCS. Some water evaporated. The remaining water flowed out of Unit 4 in the direction of Units 1 and 2.

As a result of the damage to the building, an air flow through the core was established driven by the high temperatures of the core. The temperatures of the core region could not be measured and so the behaviour of the graphite and the fuel cannot be described fully. It was observed that during the first day steam was escaping from the reactor, while from the second day on a small amount of dark smoke was observed. It is evident that the graphite reacted with air and steam. Soviet experts assess that at least 10% of the graphite burned, though this may be an underestimate: it would not be surprising if much more graphite actually reacted.

A variety of materials with a total weight of 5000 tonnes was added to the reactor vault by the response teams. This measure obviously decreased the air flow and the release of fission products though it also decreased the heat losses to the environment.

The crew succeeded in injecting nitrogen into the lower part of the building. Some pipes were cut to direct the flow, though the different flow paths are not known.

By means of gamma measurements from the outside of the concrete biological shield it was assessed that most fuel is below the core in the compartment with the water pipes. Some fuel is expected to be in the area of the horizontal outlet pipes. These measurements showed also that some fuel remained within the core, mainly

This publication has been superseded by INSAG-7

in the outer peripheral part. How this fuel is fixed within this volume is not yet clear. Of the fuel, 3–4% was ejected either in the form of fragments (on the site only) or as particles with diameters ranging from less than 1 micrometre up to tens of micrometres.

The concrete plate below the reactor was not melted through. The degree of melt–concrete interaction cannot be assessed at this stage.

3. CHRONOLOGY OF EVENTS

3.1. Chronology of events up to the rapid power increase

The detailed sequence of events shown in Table I refers to the description in the Soviet Working Documents. Figure 1, taken from these documents, is included at the end of the report for reference. It shows the time variation of reactor parameters in the simulation of the accident.

The italics in Table I indicate the major violations and important features which ultimately led to the disaster. The superscripts refer to the corresponding letters in the text.

3.2. Chronology of events after the rapid power increase

The precise subdivision into time intervals (relative to zero at the time of the first explosion) given in this subsection is not known; it is used only to organize the sequence. No importance is attached to the exact interval boundaries.

Around the time of the first explosion

Fuel within about 30% of the volume fragmented, leading to an interaction with surrounding water and subsequent steam production and pressure increase. Some hydrogen might have been produced.

Some fuel channels were destroyed, owing to loads from radiation heat transfer, impinging material and overpressure. The locations of ruptures are expected to be near the location of the power excursion, the closing plugs of the fuel channels or the pipes above the upper core plate, and the bends of the inlet pipes below the lower core plate.

Some fuel or cladding or channel material was ejected through the roof of Unit 4.

Two to five seconds later

Pressure increased perhaps to several megapascals (several tens of bars) within the reactor space owing to steam from the primary circuit, and steam was produced during and after the fragmentation process.

This publication has been superseded by INSAG-7

Upper core plate (about 1000 tonnes) started lifting with subsequent rupture of all fuel channels, lifting of control rods and shearing of horizontal pipes.

A second explosion occurred two to three seconds after the first explosion. It is not yet clear whether a second power excursion or exploding hydrogen led to this explosion.

Fuel displacement continued into the compartment below the lower core plate and into the area of the horizontal pipes.

The graphite blocks were displaced radially, also damaging the water filled shielding tank.

Within several minutes

Steam and water from the blowdown of the system inventory and water from the shielding tanks were released into the core volume, the reactor hall and the compartment below the lower core plate.

Possible reactions with graphite, zirconium and fuel.

On the first day

Water was injected into steam separators and headers soon after the accident for about half a day using auxiliary feedwater pumps, with a mass flow rate of 200–300 tonnes/h.

Water injection was stopped owing to the danger of flooding Units 1 and 2.

Steam escaped from the reactor.

Air flow established through the core region driven by high core temperatures.

From the second to the tenth days

Dark smoke resulting from reactions with graphite escaped from the reactor.

Dumping of sealing and filtering material.

Injection of nitrogen through the reactor core starting from 5 May.

4. MAIN CONTRIBUTING FACTORS

The foregoing account is based on the Working Documents submitted and information volunteered by the Soviet experts. On the basis of this information we have a plausible explanation for the sequence of events at Chernobyl Unit 4, and no attempt has been made to find alternative explanations. In our view the main contributing factors to this accident are as follows:

Disabling of automatic trips

Had these trips not been disabled, the insertion of the emergency rods would have terminated the transient regardless of all other circumstances. It is worth repeating that this test could have, and should have, been carried out in such a way that the reactor tripped as the test began. This was the intent of the test procedure and it was ignored.

Operation at unacceptably low power levels

Following the power reduction, the reactor power fell significantly below the minimum permitted level for continuous operation (700 MW(th)) owing to incorrect control system transfer. This level is set to avoid the reactor's being operated in a condition where an increase in power results in a still larger power rise. The larger the void coefficient and the lower the power level, the stronger is this effect. The experiment should have been terminated under these conditions.

Not only was the decision made to proceed, but it was also accompanied by a series of additional actions that increased the vulnerability of the reactor to low power operation still further. These actions, connecting the additional pumps and increasing feed flow well above normal balance levels, created the conditions for an accelerating power rise.

Just prior to tripping the turbogenerator, the feedwater flow was sharply reduced.

The automatic regulating rod system successfully compensated for this reduction but did not have enough residual capacity after doing so to compensate for the reduction in main flow when the test started. Without emergency shutdown protection this accelerating power rise was uncontrolled.

The dominant effect was the way that the operation of the plant determined the high value of the void coefficient; the same actions also introduced unacceptable distortions in the control rod configuration and markedly reduced the main coolant subcooling. The important factor remains the adverse modification of the void coefficient as a dominant component of the power coefficient under these conditions. Note that the RBMK reactor design is not subject to such difficulties in full power operation.

The decision to proceed with the test

The test was begun under conditions different from those specified and continued despite evidence that the plant was difficult to control and the 'reactivity reserve' condition had been violated.

This publication has been superseded by INSAG-7

All the above items have a rather similar flavour and concern the attitudes and actions of staff and management. These attitudes seem to have been conditioned by overconfidence stemming from successful, trouble-free operation, and an urge to conduct the test.

Interaction with plant design

Physics characteristics

One of the inherent features of the RBMK reactor is its positive void coefficient of reactivity. While there is no doubt that reactors with such characteristics can be operated safely, careful attention must be paid to the design of safety and control systems. Shutdown systems must be designed with sufficient speed and reactivity worth to overcome the maximum positive reactivity added by coolant voidage for all design basis accidents. The potential for misunderstanding of the physics characteristics by operators should be minimized by design features.

Containment

The lower and outer concrete structures withstood the loads from the power excursion and the subsequent loads. The pressure suppression system was not affected and had no impact on the accident or the damages. However, it is evident that the radiological consequences of the accident were exacerbated by the lifting of the upper plate.

5. REMEDIAL ACTION

The causes of the accident were numerous. In combination they caused a disaster. Regarding the issues of procedures, staff performance and management action, the Soviet experts indicated a general intent to strengthen them. Regarding the design features with which the errors and misjudgements interacted, more may be said. It has been recognized that the vulnerability to gross mishandling must be corrected and several steps are being taken.

To prevent development of a control rod configuration which violates the demand for an appropriate 'reactivity reserve', all rods will be fitted with limit switches ensuring a minimum insertion of 1.2 m, and 70–80 rods will be kept within the core. These two steps will also greatly reduce the value of the void coefficient of reactivity, and the overall protection against design basis faults will undoubtedly increase. Violation of the requirement to avoid operating below 700 MW(th) will be prevented by additional shutdown protection.

These short term measures are being implemented soon. In the longer term, to mitigate the problem of the positive void coefficient, fixed absorbers will be

This publication has been superseded by INSAG-7

installed and the fuel will be modified by increasing its enrichment from 2.0% to 2.4%. Another longer term development which is most welcome is a fast acting shutdown system, options for which are being studied.

6. LESSONS AND RECOMMENDATIONS

The general points which an understanding of the Chernobyl disaster brings to mind are as follows:

- (a) Nuclear plant designs must be as far as possible invulnerable to operator error and to deliberate violation of safety procedure.
- (b) Procedures relating to the operation of the plant must be most carefully prepared with the safety significance of what is intended continuously in view. This is particularly important for cases where unusual operations are intended.
- (c) When special procedures are intended, whereas the initiative and indeed the detailed intent might be in the hands of specialists, the ultimate responsibility for the safety of the operation must lie with the plant management. In such work, an evaluation of the intent from the safety point of view must be provided by staff with a broad understanding of all the implications. It is also important for the technical specialists to be directly involved in the performance of the special work on the plant, though no overriding authority in safety matters is implied by this.
- (d) In the final analysis, reliance on operating staff to follow defined procedures is necessary. To ensure that they do so, an appropriate atmosphere giving the right balance between performance pressures and safety is necessary, in which 'quality' checks are made on operational safety practices and tedious and demanding safety practices are seen as a benefit rather than a hindrance.

In addition, the following recommendation is made:

To assess further the different phenomena and the sequence of events after the power surge, it is essential that additional study and tests of the separate effects be performed. Most importantly, material from the core volume should be analysed. Further analysis will provide better understanding of the accident and damage progression.

This publication has been superseded by INSAG-7

Section II

THE RADIONUCLIDE RELEASE FROM THE ACCIDENT

Releases of radionuclides during the accident at Chernobyl have had severe effects in the Soviet Union and have been the cause of public concern in much of western Europe. The timing and duration of the release processes were unusual in comparison with expectations based on severe accident analyses done for reactors of other types. Furthermore, the isotopic content and character of the materials released do not conform closely to those found in previous accident analyses. The radionuclide release observed during the Chernobyl accident presents a unique opportunity to examine the current capabilities for estimating radionuclide source terms in severe accidents.

1. INFORMATION PROVIDED BY THE SOVIET UNION ON THE RADIONUCLIDE RELEASE

The Soviet experts provided information in the Working Documents and during the Vienna Post-Accident Review Meeting on the total radionuclide release, the time dependence of the radionuclide release and the isotopic composition of the released material. A summary description of this information is presented in what follows. It should be noted that some of the data provided by the Soviet Union are preliminary and are intended to be illustrative. A great amount of additional data has been gathered in the Soviet Union and these data are being processed now.

1.1. Radionuclide inventory of the core and the total radionuclide release

The Chernobyl Unit 4 core contained a radioactive inventory of about 4×10^{19} Bq (10^9 Ci) at the time of the accident. The isotopic composition of this inventory is shown in Table II.

On the basis of radiation measurements and various technical analyses of samples taken from a 30 km radius around the Chernobyl plant and throughout the Soviet Union, the experts from the Soviet Union estimate that about 1×10^{18} to 2×10^{18} Bq (3×10^7 to 5×10^7 Ci) were released from the fuel during the Chernobyl accident, not counting contributions to the release by the noble gases xenon and krypton. These estimates have an error of $\pm 50\%$. The integrated releases of individual radionuclides estimated by the Soviet experts are shown in Table II. Noble gases are thought to have been completely expelled from the fuel. About 10–20% of the volatile radionuclides iodine, caesium and tellurium were expelled from the fuel. Releases of the more refractory radionuclides, barium, strontium, plutonium, cerium, etc., amounted to 3–6%.

TABLE II. CORE INVENTORIES AND TOTAL RELEASES

Element	Half-life (d)	Inventory ^a (Bq)	Percentage released
85-Kr	3930	3.3×10^{16}	~100
133-Xe	5.27	1.7×10^{18}	~100
131-I	8.05	1.3×10^{18}	20
132-Te	3.25	3.2×10^{17}	15
134-Cs	750	1.9×10^{17}	10
137-Cs	1.1×10^4	2.9×10^{17}	13
99-Mo	2.8	4.8×10^{18}	2.3
95-Zr	65.5	4.4×10^{18}	3.2
103-Ru	39.5	4.1×10^{18}	2.9
106-Ru	368	2.0×10^{18}	2.9
140-Ba	12.8	2.9×10^{18}	5.6
141-Ce	32.5	4.4×10^{18}	2.3
144-Ce	284	3.2×10^{18}	2.8
89-Sr	53	2.0×10^{18}	4.0
90-Sr	1.02×10^4	2.0×10^{17}	4.0
239-Np	2.35	1.4×10^{17}	3
238-Pu	3.15×10^4	1.0×10^{15}	3
239-Pu	8.9×10^6	8.5×10^{14}	3
240-Pu	2.4×10^6	1.2×10^{15}	3
241-Pu	4800	1.7×10^{17}	3
242-Cm	164	2.6×10^{16}	3

^a Decay corrected to 6 May 1986 and calculated as prescribed by the Soviet experts.

1.2. Rates of release

The release of radionuclides from the Chernobyl plant did not occur in a single massive event. Rather, only about 25% of the release took place during the first day of the accident. The rest of the release of radioactivity occurred as a protracted process over a nine-day period. Throughout this time, samples of the air and ground deposits in the Soviet Union were obtained. From these data the Soviet experts constructed the time dependent release rate curve shown in Fig. 2.

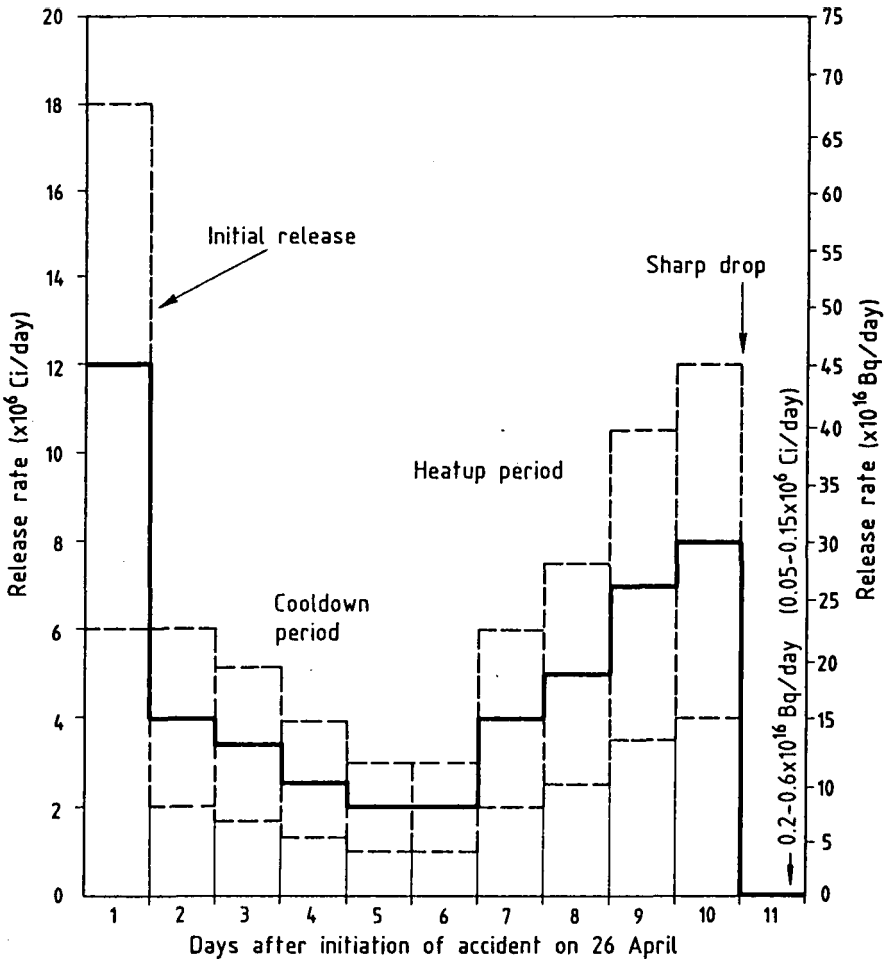

FIG. 2. The daily release of radioactive substances to the atmosphere during the Chernobyl accident (not including noble gases). The values shown are calculated for 6 May 1986 taking into account radioactive decay up until then. The radioactivity released on 26 April 1986 was $75-80 \times 10^{16}$ Bq ($20-22 \times 10^6$ Ci). The range of uncertainty for all releases is $\pm 50\%$.

The release rate curve can be categorized into four segments:

- (1) The initial, intense release on the first day of the accident;
- (2) A period of five days over which the release rate declines to a minimum value six times lower than the initial release rate;
- (3) A period of four days over which the release rate increases to a value which is about 70% of the initial release rate;
- (4) A sudden drop in the release rate nine days after the accident to less than 1% of the initial rate and a continuing decline in the release rate thereafter.

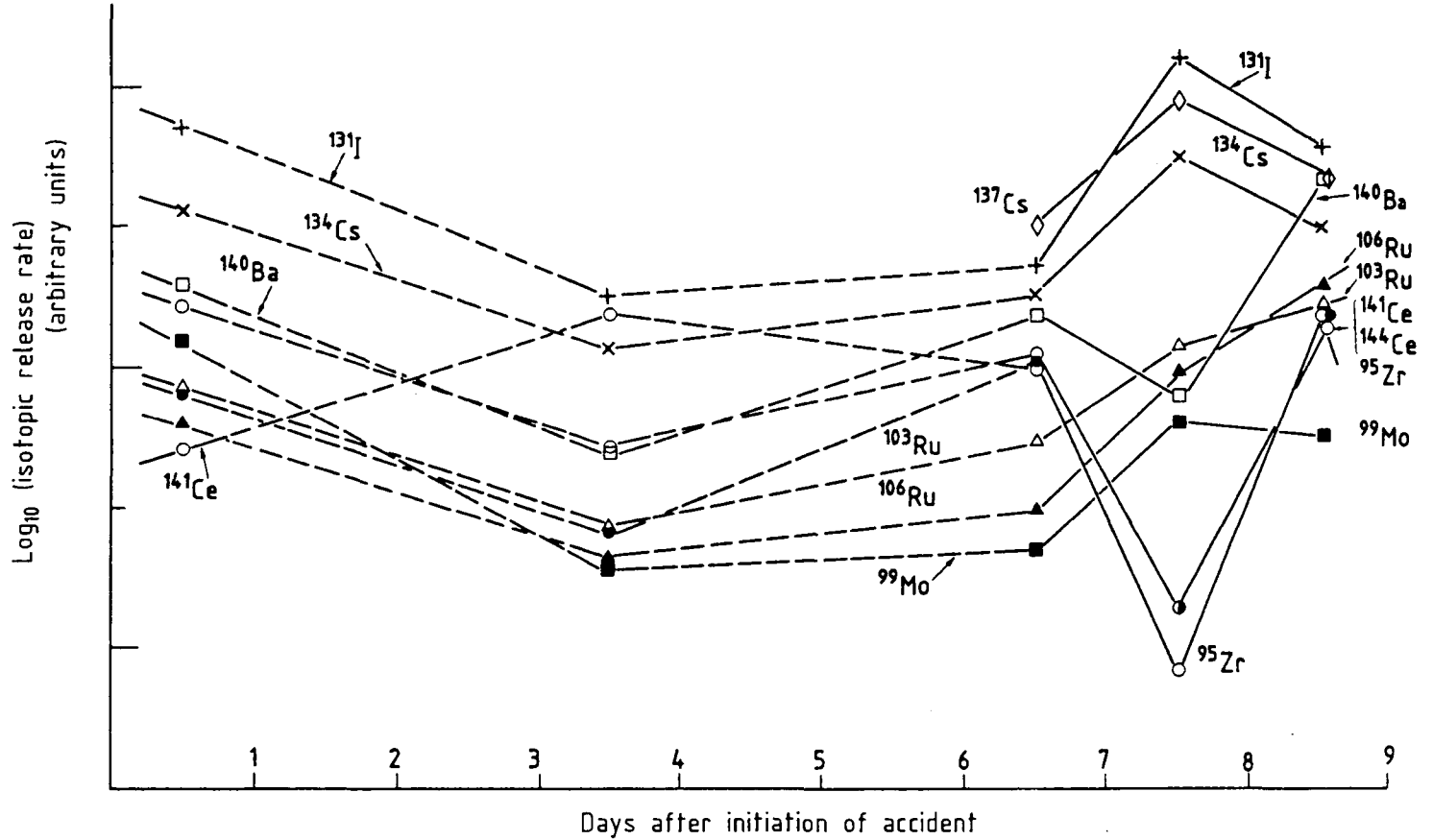

FIG. 3. Isotopic release rates derived from data provided in the Soviet Working Documents. Note that these data are preliminary and may not be representative of all the data collected by the Soviet experts.

The distribution of fuel deposited around Chernobyl was as follows:

- (a) On-site: 0.3–0.5% of the core
- (b) 0–20 km: 1.5–2% of the core
- (c) Beyond 20 km: 1–1.5% of the core.

Samples of UO_2 were found to be oxidized to U_3O_8 .

1.3. Compositions of the material released

The release of radioactivity can be further described by releases of individual radionuclides. The Soviet experts provided compositions of air samples taken during the release. From these data and the total release rate data, tentative isotopic release rates for individual radionuclides can be constructed, as shown in Fig. 3. Chemical forms of the aerosolized materials were said to be quite variable.

Particle sizes of aerosols evolved from the Chernobyl reactor core were in the broad size range of less than 1 micrometre to tens of micrometres.

2. DISCUSSION OF RELEASE IN TERMS OF MECHANISMS

2.1. Categorization of release mechanisms

Future understanding of the data presented will rest on the following well known features of radionuclide release and aerosol generation.

- (1) Vaporization release. At elevated temperatures radionuclides can undergo a condensed-to-vapour phase change and the vapours are swept away from the fuel. Vaporization release mechanisms are the predominant feature of modern tools for source term prediction. Aerosols produced by vaporization processes need not have compositions similar to that of the original fuel. It is usual to have such aerosols enriched relative to the fuel according to the vapour pressures of the species.
- (2) Mechanical release. Comminution of the fuel can produce particles of aerosol dimensions (<10 micrometres). The mechanically produced particles have, initially, exactly the same chemical composition as the fuel from which they are produced. This similarity of composition need not be preserved. As mechanically produced aerosols are swept away, volatile constituents may quickly vaporize since the aerosols have such high surface area to volume ratios (around 3000 cm^{-1}). Consequently, the mechanically produced aerosols can be deficient relative to the fuel in some volatile constituents. On the other hand, as mixtures of vapour and mechanically produced aerosols cool, the surfaces of the mechanically produced aerosols are preferred sites for condensation of the vapours. Consequently, mechanically produced aerosols

This publication has been superseded by INSAG-7

can, after cooling, be enriched in some radionuclides — especially the more volatile radionuclides. Thus, the composition of aerosols is not an infallible indicator of mechanical aerosolization processes.

Aerosols produced by either mechanical or vaporization processes may be trapped within the plant. These particles, however, may be only temporarily removed from the radionuclide emissions from the plant. Heating of structures as the accident progresses can lead to the revaporization of volatile radionuclides deposited on surfaces. Sudden increases in gas flow velocities can cause deposited particles produced by any mechanism to be resuspended. These revaporization and resuspension processes might complicate significantly the apparent relationship between radionuclide release and core debris behaviour.

Both vaporization release mechanisms and mechanical release mechanisms could be initiated by physical or chemical processes affecting the core during an accident. For instance, accelerated, liquid fuel would, because of hydrodynamic instabilities, disintegrate into droplets which can be of aerosol dimensions. At the same time, gas phase mass transport from the surfaces of the accelerated fuel would be efficient so that vaporization release from these surfaces would be rapid.

The pattern of radionuclide release observed during the Chernobyl accident should be a manifestation of processes taking place within the fuel. One of the interesting challenges for future analysis will be the consideration of the observed release data in terms of the mechanisms operating during the four stages of the release.

Of the questions remaining to be answered in this area, two stand out. Perhaps the most unusual feature of the release is its increasing rate beginning about six days after the accident. No definitive explanation for this has been offered. Among possible explanations are the following, either individually or in combination:

- (a) Once material deposition was stopped (about 3 May), heat losses from the debris declined, the temperatures rose and vaporization releases were enhanced;
- (b) Some increase in gas flow over the debris occurred which enhanced material removal by vaporization or enhanced the chemical reactions in the debris;
- (c) The melting of deposited lead and the pyrolysis of dolomite came to an end, so heat losses from the debris dropped, the temperature of the debris rose and vaporization release again increased;
- (d) Enhanced oxidation from some unidentified mechanism.

Reference to some well known properties of core debris taken from severe accident analyses for reactors of other types can be valuable here. Reheating of the mixture of core debris can have significant effects on its properties. Above about 1500 K, zirconium alloy cladding and uranium fuel do not form a compatible material combination. The high oxygen solubility in metallic zirconium and the capacity of uranium dioxide to assume variable stoichiometries mean that there can be a strong

interaction between the clad and the reactor fuel. Only kinetic factors prevent this interaction from developing at low temperatures. The kinetic barriers become less important with increasing temperature. At the core debris temperatures expected to have been reached the interaction may have occurred.

Of perhaps greater interest than its acceleration is the sharp arrest of the release. Again, no definitive explanation of this sudden arrest is available. A hypothesis that is not easily refuted is that the release accelerates because core debris reheats and liquefies. The required temperature for liquefaction is 2300–2900 K depending on the amount of unoxidized zirconium in the debris. Vaporization accelerates upon debris liquefaction. The liquefied debris can relocate, eventually falling into the lower pipe runs where it can freeze. Continuing cooling flows of gas into the pipe runs prevent the quenched debris from either melting or significantly attacking concrete and steel structures in this part of the reactor.

A second hypothesis is also tenable. The measures taken to reduce the temperature of the damaged core may well have simply reached a successful outcome.

3. RETENTION OF RELEASED MATERIALS

Escape of radionuclides from the fuel does not imply that these radionuclides escaped the plant. Once released from the fuel, radionuclides must still negotiate the pathway from the debris to the breach in the plant boundary. In the damaged Chernobyl plant there were some opportunities for entrapment of released materials. Aerosols could diffuse to or impinge on graphite surfaces above the core debris. Provided satisfactory descriptions of the geometry can be obtained, there is rather good technology available for predicting aerosol deposition on graphite surfaces in the Chernobyl reactor vault.

Particles that emerged from the flow channels could be entrapped by the dolomite, sand and clay beds deposited on the core debris. The efficiency of this entrapment is a strong function of aerosol particle size, the depth of the bed and the particle size of the bed material. Caesium could have chemically reacted with boron oxides formed on deposited B_4C or with silica in the sand and clay. Tellurium could have chemically reacted with deposited lead or with residues of steel structures above the core. As noted in the previous subsection, these mechanisms might produce only temporary retention of the released radionuclides.

Once aerosol particles emerged from the vault region at the Chernobyl plant, the surface areas available for aerosol deposition were too small significantly to affect subsequent releases from the plant.

4. IMPLICATIONS OF THE CHERNOBYL RADIONUCLIDE RELEASES FOR THE TECHNOLOGY FOR ESTIMATING SEVERE ACCIDENT SOURCE TERMS

The Chernobyl accident provides a demonstration of several features of radionuclide releases that had, in the past, been merely predictions and subject to technical controversy. It is now confirmed that extensive releases of radioactive materials can occur in a severe reactor accident. Further, it is clear that the materials released can be transported considerable distances from the reactor. Some caution is necessary in going beyond these qualitative demonstrations confirming past assumptions and predictions to draw conclusions concerning the general adequacy of current technology for estimating severe accident source terms. This caution arises because the RBMK reactor and the Chernobyl accident may involve unique features with unappreciated effects on the radionuclide release. There are some conclusions that can be drawn, however:

- (1) **Modelling of release from the plant:** Radionuclide release from the Chernobyl plant did not occur as a single acute event. Rather, only about 25% of the release occurred initially. The balance of the release occurred over a protracted period during which time the conditions affecting the formation of a radioactive plume and the dispersal of radioactive material away from the site changed considerably. This characteristic of an intense initial release followed by a protracted, but less intense, release of radioactivity is often predicted for accidents involving plants of designs considerably different from that of the RBMK.

It appears, then, that dispersal of the radioactivity away from the reactor site and the release of radioactivity from the fuel cannot be treated as completely separate processes. Dispersal modelling needs to be included as an element of the technology for estimating source terms.

- (2) **Mechanical release processes:** There are suggestions of considerable radionuclide release by mechanical comminution of fuel. During the initial phase of release, this mechanical aerosol formation may be the result of (a) melt interactions with water; (b) expulsion of core debris into an oxidizing environment; or (c) the peculiar features of the reactivity insertion event. There are as yet no adequate models for the releases associated with these events.
- (3) **Delayed acceleration of release:** Current procedures for estimating severe accident source terms do not permit a satisfactory rationalization of either the acceleration in the rate of radionuclide release observed at Chernobyl, beginning about six days after the start of the accident, or the sharp reduction in the release rate about nine days after the start of the accident. Accentuation of volatile releases (such as releases of caesium, iodine and tellurium) may be the

This publication has been superseded by INSAG-7

result of increased temperatures of the core debris or the result of heating structures sufficiently to revaporize volatile radionuclides deposited on these structures.

The accelerated releases of more refractory radionuclides (such as barium, strontium, cerium, lanthanum, ruthenium and molybdenum) seem to require very dramatic alterations in the conditions of the core debris. Melting of the core debris and relocation of this debris from the reactor vault to the lower pipe runs might account for accelerated releases of these refractory radionuclides. Preliminary examinations suggest that available models may not include the physics and chemistry essential to describe quantitatively the accelerated releases of both refractory oxides (BaO , CeO_2 , etc.) and refractory metals (ruthenium, molybdenum, etc.).

5. RECOMMENDATIONS CONCERNING FOLLOW-UP WORK AND ACTIVITIES INVOLVING INTERNATIONAL CO-OPERATION

The Soviet reports provide a good deal of information on radionuclide behaviour. Still more data are needed for a detailed understanding of the relationships between the behaviour of core debris and the radionuclide release. Further examination of the accident phenomena is clearly merited.

- (1) Chemical and physical forms of the materials released: At this early stage after the accident, it has not been possible to collect data on the chemical form of radionuclides released from the plant or the physical forms of the particulate material. Data on the chemical form and the physical size distribution of the particles are indicative of the nature of release processes. These data are essential inputs for models of debris dispersal. The data on chemical form are also useful for predicting the subsequent behaviour of particles once deposited on the earth.
- (2) Chemical state of the core debris: Possible explanations of the releases of radionuclides during the Chernobyl accident cite chemical interactions of the debris either with graphite or gases passing through the core. Definition of the current chemical state of the core debris in both the reactor vault and the lower pipe runs would clarify the possible contributions of chemical reactions of core debris to the observed releases of radionuclides.
- (3) Assessment of accident management strategies: The general field of accident management techniques is still in its infancy. The Soviet strategy of depositing materials on the core seems to have been quite effective at minimizing the radionuclide release. The materials deposited in the reactor vault may have kept the core debris temperatures sufficiently low to minimize the release or they may have filtered the particulate from the evolved gases. It would be useful, then, to extract some of the deposited materials and examine them to

This publication has been superseded by INSAG-7

ascertain which of these possible effects were of predominant importance. Some specific questions concerning this deposited material are as follows:

- (a) Did B_4C oxidize to B_2O_3 and did this B_2O_3 react with evolved radionuclides?
- (b) Did the dolomite decompose?
- (c) To what extent were radionuclides physically entrapped in the debris?

The follow-up actions lead naturally to several areas of international co-operation. Three such areas that can immediately be suggested are:

- (1) Source term research: The period of the study and the technology immediately available preclude a quantitative explanation of the releases of radionuclides observed during the Chernobyl accident. This is particularly the case for the releases occurring during the first day, which may have involved release associated with core debris dispersal in flow channels, core debris-water interactions and debris dispersal into oxidizing environments. There is current research on some of these topics, particularly in the United Kingdom, the United States of America and the Soviet Union. In some cases, the implications of the phenomena for the source term have not been considered in this research. Exchanging information between the researchers and encouraging the inclusion of source term studies in the research could be fostered by the IAEA, and would promote the more detailed understanding of the Chernobyl releases and help bring this issue to closure.
- (2) Coupling release and near-field dispersion modelling: The IAEA could encourage the coupling of models for predicting radionuclide release and dispersal of released material from a plant so that more realistic assessments of the radiological consequences of severe accidents could be made. 'Standard problem' exercises for the various modelling capabilities could be envisaged. For instance, such standard problems might entail:
 - (a) Protracted release and dispersal from a plant with an open core but without a pressure-containing containment;
 - (b) Acute release and dispersal from an overpressurized containment, including the effects of pool flashing and steam condensation.
- (3) Accident management actions to minimize radionuclide release during severe accidents: The IAEA could foster the international exchange of ideas and experimental results on strategies for minimizing radionuclide releases during severe accidents.

Section III

THE RESPONSE AT THE SITE

The on-site response measures occurred in the following three stages:

- (1) The fire-fighting actions to control and finally to extinguish the fire;
- (2) The short term stabilization of the plant immediately following the accident;
and
- (3) Long term recovery, including the entombment of the damaged unit and monitoring the long term integrity of the entombed core debris and reactor building.

The fire-fighting measures which were employed proved to be very effective and contributed significantly to preventing the spread of the fire into Units 1, 2 and 3. Intense radiation fields were the most serious complicating factor in the fire-fighting efforts.

The short term stabilization and the long term recovery of the plant relate directly to and strongly depend on the accident physics and radionuclide releases (source term) described in Sections I and II. These stabilization efforts were aimed at inhibition of both the graphite fire and the evolution of radionuclides. Decontamination of the site itself was an important recovery action.

The accident management actions taken at Chernobyl were, generally, quite successful. The first attempt to supply water to the core from emergency auxiliary feed pumps to quench the core debris was apparently unsuccessful and quickly abandoned. The subsequent steps, namely dumping materials into the reactor well (boron carbide, dolomite, sand and clay, and lead), supplying nitrogen to bring down the temperature in the core space and to reduce the oxygen concentration, and construction of a flat heat exchanger beneath the foundations of the reactor building, stabilized the situation at an early stage (about nine days after the initiating power surge) of the accident.

The radiological site evaluation carried out immediately after the accident provided information on the state and location of the fuel, the state and location of graphite ejected from the core space by explosions, and preliminary information on the chemical forms of the discharged materials. The radiological and locational measurements were carried out inside and outside the damaged unit. These were *significantly complicated by the fact that the regular measurement systems in the plant had broken down completely*. The outputs of detectors which might have survived were inaccessible to the plant personnel because of the radiation field.

The measurements provided the basis for establishing long term techniques to monitor the state of the core debris in the reactor building and the basic design requirements for the entombment construction, such as the temperature and location of the core debris, limits on radiation levels to be achieved after the construction

This publication has been superseded by INSAG-7

(5.0 mR/h at the roof and 1.0 mR/h at the site walls), forced ventilation schemes based on convective air flow, and the long term stability of materials (primarily concrete) being used for the entombment.

Clearly, the information provided in the Working Documents and the discussions indicates the importance of accident management. The technology of on-site nuclear accident management has been an area of interest in other countries but attention to this aspect of nuclear safety has necessarily been largely theoretical. Consequently, the practical and very successful accident management experience at the Chernobyl site is of great interest, and should be further analysed and documented.

1. FIRE-FIGHTING

The description of fire-fighting during the Chernobyl accident provided by the Soviet experts was fairly complete. It provided many valuable observations applicable to fires at all nuclear power reactors regardless of the cause.

Shortly after the accident at Chernobyl Unit 4, three fire-fighting teams left the towns of Pripyat and Chernobyl to provide additional capacity to the teams at the site. One of the most important requirements in any fire-fighting, including that at Chernobyl, is to gain time to put various schemes into action. The lack of special equipment (hydraulic lifters) to place fire-fighters on the roofs was mentioned. The two explosions occurred around 01:24; the fires on the roofs of Units 3 and 4 were localized at 02:10 and 02:20 respectively, and the fire was quenched at 05:00.

The main challenges were to prevent the fire from spreading to Unit 3, to localize the fire on the roof of the common machine hall of Units 3 and 4, to protect the undamaged parts of Unit 4 (the control room, inside the machine room, the main circulating pump compartments, the cable trays), and to protect the flammable materials stored on-site, such as diesel oil, stored gas and chemicals.

The fire-fighters were called upon to extinguish burning ejected graphite blocks and segments. The basic techniques used, successfully, were isolation and water quenching of the graphite blocks. The fire teams experienced no unusual problems in using their fire-fighting techniques, except that it took a considerable time to extinguish the graphite fire. The radiation field generated during the accident was, of course, a source of many difficulties in the fire-fighting. Further discussions of this problem are presented in Section IV.

The fire-fighting methods used primarily included the application of water, foam sprays and gas. The water was used to extinguish fires on roofs, cable rooms and on other surfaces, and to put out fires on graphite and other material and structural debris. The foam sprays were mainly applied in rooms and areas containing flammable materials such as diesel oil, chemicals, cables, etc. Gas was available but

not used for fire-fighting in the control room. The use of foam sprays was believed to contribute to inhibition of the resuspension of deposited radionuclides.

The immediate protection of site personnel was of prime concern. In order to protect against smoke and fire, a preplanned evacuation took place to designated fire protection areas.

The fire at the Chernobyl site had features that could in some respects be said to be generally characteristic of fires at nuclear power installations, and other features that were unique. Firstly, at Chernobyl there was a combination of fire and high radiation fields. It appears that these conditions would require further improvement of fire-fighting equipment designed to cope with extreme conditions and radioactive materials (fuel, burning graphite, etc.). There is a need for the development of scientific and technical measures directed towards improved effectiveness in extinguishing fires and preventing the spread and transport of radioactive material that may be involved (fire-fighting with specific provisions for nuclear safety). Methods and equipment might include automated systems for monitoring and detection, fire-fighting robots, the use of less flammable turbine oils, etc. Secondly, there is a need for lightweight clothing, not only to protect the fire-fighters from the high temperatures, but also to provide protection from radioactive contamination.

2. ACCIDENT MANAGEMENT

Accident management at the early stage was aimed at inhibiting the combustion of the graphite and preventing processes in the core region that might have led to further release of radionuclides.

The destruction of all of the fuel channels, the destruction of the upper pipe interface, the lifting and twisting of the upper plate cover, and the destruction of the lower water interface (pipes) were probably responsible for the lack of success in introducing water into the reactor core. The water fed in by the emergency feedwater pumps went to other parts of the damaged primary circuit. The fact that steam and white smoke from the reactor well were observed on the first day suggests that water contacted hot material within the reactor vault. On the second day, no steam was seen emerging from the reactor well. The water flow was stopped when it was realized that contaminated water was flowing from Unit 4 towards Units 1 and 2.

The water introduced possibly contributed to some small production of hydrogen and carbon monoxide, adding somewhat to the heat source, but it must have substantially drained out of the plant. The overall contribution was probably negligible.

On 28 April a massive accident management operation began. This involved dropping various materials into the reactor well from helicopters. The materials dropped onto the core were:

This publication has been superseded by INSAG-7

- (1) Boron carbide (B_4C) to ensure against recriticality;
- (2) Dolomite ($(MgCa)(CO_3)_2$) to generate carbon dioxide that could provide 'gas blanketing' and could contribute to dissipating the internal heat within the core space (by absorbing the energy of the burning graphite);
- (3) Clay/sand to introduce an immediate filtration for radionuclides being released and to quench the fire; and
- (4) Lead (Pb) to absorb heat by melting and to provide a liquid layer that would in time solidify to seal and shield the top of the core vault.

The estimated amounts of materials dumped on the core were:

- B_4C : 40 tonnes
- Dolomite: 800 tonnes
- Clay/sand: 1800 tonnes
- Lead: 2400 tonnes.

On 4 May or 5 May a system was installed to feed cold nitrogen to the reactor space. The aim was to provide additional cooling of the core debris and to blanket against oxygen. The nitrogen pressure was provided by the station compressor and the nitrogen was pumped through the lower piping underneath the reactor.

By 6 May the core temperature had fallen and stable convective flow of air through the core space into the atmosphere above had been established. These actions apparently put the 'core debris-materials' mixture into a type of quasi-equilibrium and probably contributed to the sharp reduction in the release rate (and to final stabilization) by steadily removing heat generated by the core debris and by some filtration of radionuclides.

In addition, work started on the construction of a makeshift flat heat exchanger beneath the foundations of the reactor building. The decision to construct this was made at an early stage of the accident when the possibility of core-concrete interaction was being considered, and when very limited information existed on the physical state of the destroyed core. This work was completed by the end of June. The heat exchanger now provides an additional mechanism for heat removal.

3. BASIC ASSESSMENT OF THE ACCIDENT MANAGEMENT ACTIVITIES

Theoretical work on accident management has previously focused on the use of water to cool core debris and thus to reduce or terminate continued release of radioactivity from the plant. The use of water as the primary tool for accident management at any reactor could cause potential problems of steam generation, hydrogen production and violent fuel-coolant interactions. These potential problems have frustrated detailed development of accident management strategies in the past.

This publication has been superseded by INSAG-7

The objective in the attempts to manage the accident at Chernobyl was indeed to limit the continued release of radionuclides. The accident management team sought to accelerate the decline in the radionuclide release rate from its peak during the first phase of the accident to a negligible level. The initial measures taken used water to attempt to cool the core debris. These attempts proved ineffectual and were abandoned. The Soviet experts at the plant then began to employ novel and pioneering methods to reduce the radionuclide release. Two important methods were:

- (1) The deposition of dry, inorganic materials on the core; and
- (2) Gas blanketing of the reactor vault.

These methods are of great interest because of the considerable departure from conventional concepts and because they were eventually successful.

The techniques employed at Chernobyl open new avenues in the planning of accident management. The urgency of the accident situation at Chernobyl meant, however, that methods were employed in such rapid succession that it is not certain which of them had the most beneficial effects. Clearly it is not practicable to determine whether more nearly optimal materials and methods could have been used.

A key follow-up action to the discussions of the Chernobyl accident will be to build upon the successful experiences at Chernobyl by:

- (1) Beginning to evaluate accident management strategies; and
- (2) Selecting optimal materials for extracting heat from core debris and mitigating radionuclide release following a core meltdown accident.

There should be substantial international interest in these efforts since accident management should be a generic matter for all types of reactors.

4. RADIOLOGICAL SITE SURVEY

Radiological site surveys after the accident had two purposes:

- (1) To establish the levels of contamination that would confront personnel involved in the accident cleanup; and
- (2) To determine the location and stability of core debris within Unit 4.

Site surveys to establish contamination levels used:

- (1) Aerial gamma photography;
- (2) Aerial gamma scanning with collimated detectors;
- (3) Alpha and gamma spectroscopy and beta measurements of soil samples;
- (4) Gamma spectroscopy of aerosol samples drawn at elevations of about 3 m and 200 m on-site.

This publication has been superseded by INSAG-7

An important task was to establish the location of the fuel by gamma scanning the rooms within the plant. An initial estimate that about half of the fuel was in the machine room proved incorrect. The error was attributed to imprecise gamma scanning measurements. As the survey progressed, probes were inserted into pipes within the lower and upper parts of the core vault.

In the area of the foundation of the reactor the downcomers of the main circulating water pumps were cut and thermocouples and gamma sensors were installed in the pipes alongside the core space. The measurements indicated a radiation field of from 10^3 to 10^5 R/h, confirming the presence of fuel. The measured temperature varied over the range of approximately 30°C to 50°C depending upon whether or not air circulated through the pipes.

More detailed data are still needed before data from radiation surveys can be fully interpreted. Essential results of the radiological survey that can be summarized at this point are as follows:

- (1) Of the fuel, 0.3–0.5% was deposited on-site.
- (2) A considerable part of the core debris is located within the reactor vault between the biological shield and the remainder of the core and in the pipes running below the core.
- (3) In the area above the reactor well, temperature and gamma measurements were performed using sensors lowered from helicopters. At the approximate centre of the reactor the measurements show the radiation intensity to be higher than 10^4 R/h and the temperature to be around $300\text{--}350^\circ\text{C}$. Sensors inserted into the core have a very short life in the presence of the high radiation field and at the elevated temperatures.
- (4) At the beginning of August, special buoys were being installed in the core vault to measure gamma radiation, heat flux and air speed (horizontal and vertical). Observed temperature variations depend on wind and air speed and on other parameters not identified; measured vertical air speeds are around 0.8–1.0 m/s. The horizontal velocities are about 0.5–0.8 m/s. All the information mentioned is vital for the design of the ventilation scheme of the entombment. The measurements are complicated by distance (approximately 240 m of steel rope are used), wind, etc. Presently four buoys are in operation, but it is planned to install six additional ones.
- (5) The use of lasers at a distance of approximately 1 km to obtain measurements of aerosol size and concentration is being evaluated. Again, this is important for the future filtration system in the entombed unit.

Visual site observation confirmed that only a small amount of graphite was ejected from the plant. Most of the graphite remains in the reactor well. It is currently estimated that about 10% (250 tonnes) of the graphite burned.

Examination of graphite blocks and debris showed that the ejected graphite came largely from unfuelled regions of the core. The analyses performed to date

This publication has been superseded by INSAG-7

indicate that this graphite contains no fuel. Examination of the fission products in the ejected graphite may provide some indication of the temperatures experienced by the graphite.

Chemical and physical forms of the materials discharged from the core are currently being examined by the Soviet experts. Only a partial qualitative assessment of aerosol particle sizes can be made at this time. The sizes of on-site particles containing plutonium and transuranic elements vary from less than 1 micrometre to tens of micrometres for plutonium and some transuranic elements. Information in the future on the chemical forms would be most desirable.

5. CLEANUP OF THE SITE

The cleanup operation and decontamination started immediately after the accident and used various techniques ranging from simple washing and scrubbing to robotics. Various chemical solutions and organic sprays were used, mainly to prevent resuspension of deposited materials. In some cases concrete pads provided the necessary long term protection. The subject of the site cleanup is treated in greater detail in Section IV.

6. ROBOTICS

The use of robotics in reactor accident situations is of great interest. Information in this area in the future is of extreme importance since robotic methods might be effectively used for fire-fighting, for delivery of diagnostic devices and for decontamination.

7. DIAGNOSTIC INSTRUMENTATION

Visual and dosimetric surveys performed in various rooms and compartments and in the piping system were limited and complicated by the high radiation fields and the inaccessibility of the damaged and highly contaminated units. The regular installed measurement system had completely broken down.

In the beginning, gamma scanning was mainly used. At a later stage, temperature sensors were installed to obtain measurements at various locations, mainly in the lower piping and above the reactor well. The preliminary conclusion is that the majority of the dosimetric instrumentation did not function properly in the high radiation fields and in many cases provided erroneous or very inaccurate data. Development of radiation-hardened diagnostic equipment may well be an important activity for the future.

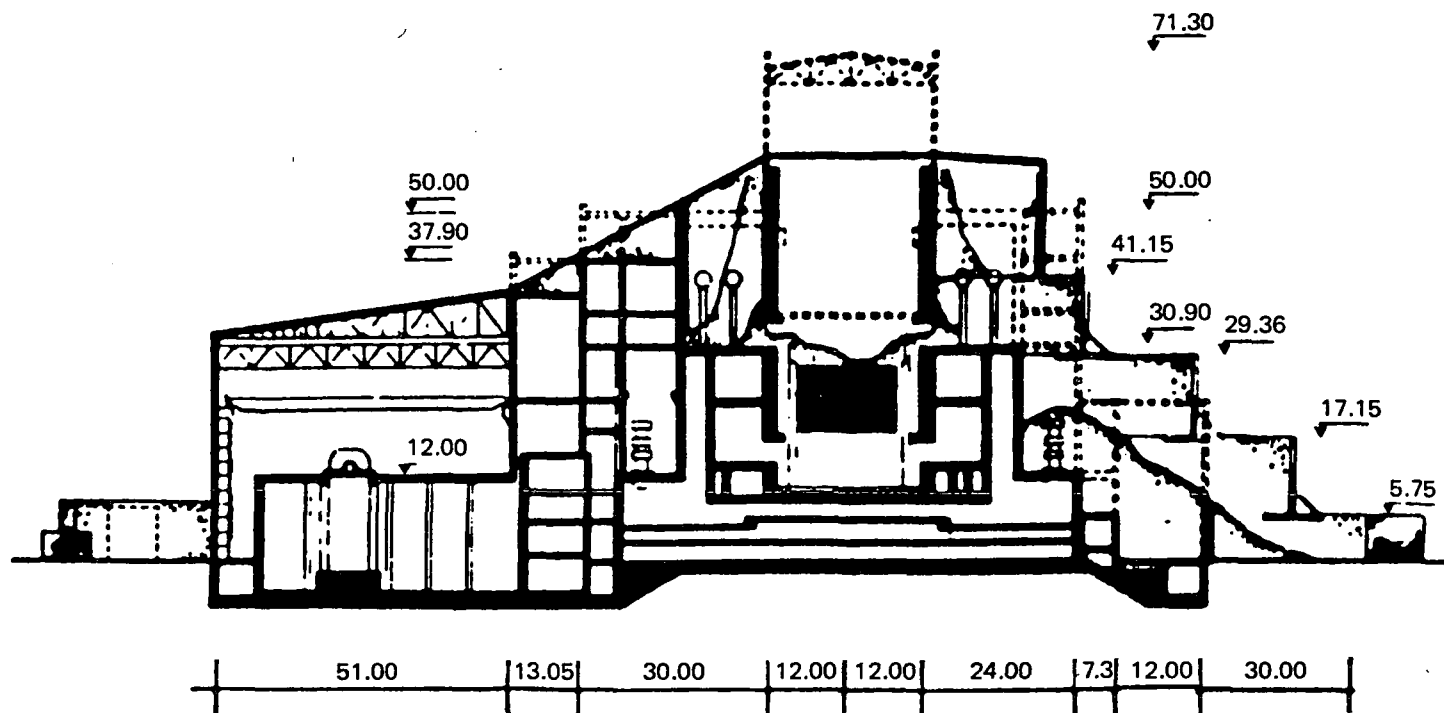

FIG. 4. Vertical section of the projected entombment structure for Chernobyl Unit 4. Dimensions are in metres.

8. ENTOMBMENT OF THE DAMAGED UNIT

Long term entombment of Unit 4 is planned, with the objective of ensuring a normal radiation field in the surrounding area and preventing the escape of radioactive materials. This will, of course, be a major technical innovation which will be of great interest to experts throughout the nuclear safety community.

The basic criteria adopted for the entombment structures may be summarized as follows.

8.1. Technical criteria

- (1) Compliance of the entombed core debris and fission products with all radiation protection criteria and standards. The goal is to achieve a radiation level not exceeding 5.0 mR/h at the roof and 1.0 mR/h at the walls;
- (2) Design levels for all natural events (such as wind, earthquake, extreme temperature) that could occur at the site, at an annual probability of 10^{-4} of excess. This is a level used for other major structures in the Soviet Union.

8.2. Criteria related to construction techniques

- (1) Minimization of construction time;
- (2) Use of the simplest, most reliable, well established means of construction;
- (3) Minimization of radiation doses to construction workers.

From the criteria in the report or given during the discussions, it is not clear whether or not the entombment is to provide a permanent repository for the core debris and fission products contained in Unit 4. Furthermore, monitoring of the parameters related to the groundwater (such as activity, temperature, etc.) has not been discussed. The scheme for permanent dewatering of the area around Unit 4 as well as the groundwater monitoring are two important topics for consideration.

The conceptual construction is shown in Fig. 4. The construction of the walls is being carried out by building terraces to seal off the reactor building step by step. The construction material is concrete. The removal of the heat will be accomplished with ventilation and filtration systems. More than ten options were examined, falling into categories of both open and closed systems.

Questions concerning the air flow path through the reactor space, possible deviations, etc., remain to be discussed.

An open system was selected primarily on considerations of ease of measurement (easier to monitor) and the possibility of changes, modifications, etc., as time progresses.

This publication has been superseded by INSAG-7

The entombment structure is envisaged to include the following:

- (a) Outer protective walls along the perimeter;
- (b) Inner concrete partition walls in the turbine hall between Units 3 and 4, in the B block, and in the de-aerator room along the turbine hall and on the side of the debris by the tank room of the emergency core cooling system;
- (c) A metal partition wall in the turbine hall between Units 2 and 3;
- (d) A protective roof over the turbine hall.

Depending on the shielding and design requirements, the protective concrete walls are to be 1 m thick or more. The effect of this new load on the foundation or leakage into the groundwater through the foundation slab were not discussed.

During the presentations it was clear that the long term stability of concrete has been considered at length. The thermal conductivity of concrete over the long term raised the question of the strength of the concrete.

The Soviet experts described experiments being carried out in the temperature range 2000–2600°C. The binder in the concrete is a mixture of calcium aluminate hydrate, $\text{Ca}(\text{OH})_2$ and CaSiO_3 hydrate which melts at about 2000°C. Most concretes melt over the range 1100–1600°C. The materials being used for experiments are castable refractories and ought not to be called concretes. Fabrication technology for castables is in its infancy. The Soviets have encountered some difficulties with this type of fabrication. The question was raised of possible thermal explosion of concrete in contact with UO_2 , but this process was considered to be highly unlikely.

Plant lifetime (i.e. the duration of exposure of nuclear power plants to extreme events) is generally taken as about 50 years. If the envisaged lifetime for the entombment structure is much longer than this period, the lifetime (not annual) reliability of this structure will be substantially lower than that of nuclear power plants. In general, the following questions can be raised:

- (1) What is the envisaged lifetime of the entombment?
- (2) If the design lifetime is much longer than about 50 years, will there be provision for the possibility of improving the design at a later stage?
- (3) How does the importance of the integrity of the structure decline with time as the levels of radioactivity within decay away?

Section IV

RADIATION PROTECTION ASPECTS OF THE ACCIDENT

1. INTRODUCTION

Section IV deals with the radiological protection aspects of the accident. Subsection 2 is a summary of some of the radiological problems encountered during the initial on-site emergency response and the conclusions which can be drawn from the Soviet experience at Chernobyl. Subsection 3 describes the off-site emergency response and the lessons to be drawn from this accident. It also identifies areas for future international work. Subsection 4 deals with decontamination of equipment and buildings at the site and of the general environment. Transport of radionuclides through the atmosphere and their transfer through the rest of the environment to man are described in Subsection 5, where estimates are given of doses to individuals and populations in the Soviet Union. Finally, the immediate and longer term health effects of the accident are discussed in Subsection 6, including in the former case the medical treatment of those exposed to high radiation doses.

2. INITIAL ON-SITE EMERGENCY RESPONSE

A number of conclusions can be drawn from the Soviet experience about future work on design of plants, operational procedures, equipment and planning for on-site emergencies.

Some of these aspects are as follows:

Equipment which is needed to mitigate the on-site consequences of accidents, such as fire-fighting systems and robots, should be incorporated in the plant design and should be available so that effective mitigation and control actions are possible without unduly exposing the emergency workers.

Appropriate protective clothing and equipment should be designed for use by fire-fighting and emergency teams in the plant. Together with anticipated high radiation fields that posed problems in themselves, there was high airborne beta contamination that caused severe beta skin burns.

A major effort was required to establish an additional dosimetric control system for personnel employed on the plant during the course of the accident and in the recovery actions. It is clear that it is essential to provide personnel with personal integrating alarm dosimeters, particularly the emergency and fire-fighting teams.

This publication has been superseded by INSAG-7

Future work should discuss the design criteria and the effects of ventilation in the early phases after the accident and the consequences for occupational radiation exposure and habitability of control rooms and vital parts of the installations, considering also the case of stations with multiple units on the same site.

Other problems are presented by the radioactive contamination and the radiation fields that were experienced in Unit 3 and Units 1 and 2. As a result of radiation levels currently experienced, the Soviet experts announced that these units will be operated in a specific manner, with frequent rotation of the operators. It is understood that operators from other nuclear power plants will be recruited on a two-weekly basis for the operation of Units 1 and 2. Such an operational mode will require enhanced attention to radiation protection issues, including collective dose issues, and an intensification of surveillance of radiation exposure. At present there is no date foreseen for the restarting of Unit 3.

Occupational radiation protection problems will arise during the decontamination of the installations and other on-site and off-site areas. Experience gained from these decontamination efforts will be very useful for others who may have to decontaminate large, heavily contaminated areas.

Radiological monitoring equipment encountered severe environmental conditions. This issue was already identified as a potential problem following the Three Mile Island accident, but the Chernobyl experience has intensified this problem and more research in this field is required.

3. OFF-SITE EMERGENCY RESPONSE

The first measures taken after it was realized that an accident had occurred at the plant and fire had developed were fire-fighting, short term operations to stabilize the plant and alerting of authorities.

The authorities in Moscow were alerted about the accident on 26 April and a specialist team was immediately dispatched to the site to assist local authorities and plant management to deal with the situation. Initially there were some problems in accurately reporting the severity of the accident situation at the plant and off-site.

On their arrival the specialist team found a very serious situation. One of the initial decisions was that a precautionary evacuation of the town of Pripyat should be carried out as soon as possible. On the morning of 26 April, people were instructed to remain indoors with windows and doors shut. Schools and kindergartens were closed.

To prevent the accumulation of radioisotopes of iodine (mostly I-131) from the plume in the thyroid glands of members of the public, potassium iodide tablets were distributed to the population of the surrounding zone. This was done by employing

This publication has been superseded by INSAG-7

volunteers to hand the tablets directly to individual residents on a door-to-door basis, starting on the morning of 26 April.

The collection and collation of meteorological and radiological monitoring data were organized. Aerial radiological monitoring (by airplanes and helicopters) was commenced. The military helicopters used during the emergency response were equipped with air samplers and radiation detection instruments and the crews were provided with personal dosimeters and respiratory protection.

Late in the night of 26 April, radiation levels in Pripjat started rising, reaching a value of the order of 10 mSv/h on 27 April. It soon became apparent that the lower intervention level for evacuation (250 mSv whole body dose) could be exceeded and eventually even the upper intervention level (750 mSv whole body dose) if the population remained in their homes and no other countermeasures were taken. Ad hoc evacuation plans, taking into account the actual situation, had to be devised as not all existing arrangements could be applied.

The evacuation of Pripjat started on the morning of 27 April, after safe evacuation routes had been established on the basis of the first results of radiological monitoring, and all the necessary transportation means, equipment and escorting personnel were gathered and relocation centres had been designated, manned and equipped. Medical resources were alerted and medical teams to assist the evacuees were promptly organized.

Of the on-site personnel, about 300 had to be hospitalized for radiation injuries and burns. Specialized treatment and care were given during the first few weeks. No individual from the off-site area had to be hospitalized for radiation injuries, although many nonetheless attended hospitals for other reasons.

Necessary provisions had to be made for the decontamination of people's skin and for the exchanging of clothing in some cases.

In the following days, the same protective actions had to be gradually applied to the other population centres in an area of radius about 30 km around the plant. In addition to people, some tens of thousands of cattle had to be evacuated from the area in hundreds of trucks.

The evacuation of the population helped in keeping the exposure of most individuals below the dose intervention level.

Measures were also taken to prevent or reduce the effects of contamination of water bodies and groundwater supplies.

During all this time extensive environmental radiological monitoring took place; contamination of a great number of foodstuffs was experienced and it was necessary to establish derived intervention levels for foodstuffs. As a consequence, the consumption of milk and other foodstuffs had to be banned over a considerable area.

Because of the contamination, the area within a 30 km radius was divided into three zones: a special zone (some 4–5 km around the plant), where no re-entry of the general population is foreseeable in the near future and where no activity besides

This publication has been superseded by INSAG-7

that required at the installation will be permitted; a 5–10 km zone, where partial re-entry and special activities may be allowed after some time; and a 10–30 km zone, where the population may eventually be allowed in and agricultural activities may be resumed, but which will be subject to a strict programme of radiological surveillance.

Access and egress controls for personnel and vehicles have been established at the zone boundaries to reduce the spread of contamination.

All the protective measures and deployment of resources and personnel were ordered and co-ordinated by a special commission.

Particular effort was required for the decontamination of equipment and off-site areas.

One general conclusion to be drawn from the actual emergency response is that although it had to be initiated at the local level, the management of the total emergency situation and response required a rapid acceleration of resource commitment. Because of the scale of the accident, such resources, and the authority for their commitment, could not be expected to exist at the local level.

It must be recognized that for any accident of this severity, irrespective of the location or country of occurrence, there will need to be a major commitment of manpower and equipment resources in order to regain control of the situation and to reduce the consequences for the population and the environment. This in turn is likely to entail a need to draw upon resources located at considerable distances and over a wide area.

Provisions for achieving this must be taken into account in the emergency planning arrangements of the plant operating organizations and public authorities by ensuring that the more limited, but detailed, formal arrangements normally provided for in the operating organization's emergency plan are capable of extension on an ad hoc basis should the need to respond to a major accident involving extensive off-site consequences ever arise.

Decontamination and emergency measures were discussed. Many questions were raised in the Meeting about emergency measures related to the following topics: the emergency response organization; emergency intervention levels; evacuation and sheltering; and iodine prophylaxis.

For each of these topics it was required to discuss the criteria for introducing the measures, the efficiency of the measures in the light of what occurred, the problems encountered in the implementation and the conclusions that could be drawn from the experience for improving existing emergency plans.

Soviet experts emphasized the importance of a centralized emergency co-ordination centre with all the authority and the powers to direct the response organization, considering all the potential problems that can arise in co-ordinating the efforts of evacuation, relocating people and cattle, monitoring, medical and social assistance, transportation and logistics. The establishment of emergency intervention levels was identified as one of the most important and most difficult areas.

This publication has been superseded by INSAG-7

It is essential to differentiate between intervention levels for actions on-site and off-site and levels for actions in relatively distant countries affected by transboundary releases. Derived intervention levels for actions should be developed internationally on a rational scientific basis. International co-operation on this matter is needed.

The short time available at the Meeting did not allow a detailed discussion of many important topics such as preplanning, evacuation and sheltering strategies, protective actions for agricultural crops, technical aspects of radiological monitoring and general emergency response, re-entry and reoccupation criteria and the problems encountered and the lessons to be learned. These should be addressed in a future meeting.

4. DECONTAMINATION

The accident caused extensive contamination of the environs by fission and activation products. All the nuclides which are produced in the fuel, including those of plutonium, have been detected. Heavy contamination, requiring extreme efforts for its control and removal, has been deposited at the site, both on inner and outer surfaces of Units 1, 2 and 3, and in a zone with a radius of 30 km surrounding the site. Approximately half of the released material was deposited within this 30 km zone.

In this zone the ground and its vegetation, buildings and water bodies were all affected. In addition, some areas outside this zone up to a distance of about 60 km showed significant contamination levels, requiring efforts to reduce them. Within the 30 km zone all inhabitants were evacuated.

In addition, large areas both within the Soviet Union and in many other countries experienced contamination. Although outside the Soviet Union the contamination levels were such that direct decontamination measures were not necessary, measures such as controlling milk, vegetables and other foodstuffs were taken in some countries in order to avoid unnecessary doses to the public.

Decontamination has started inside Units 1, 2 and 3. Because the ventilation systems had continued operation for several hours after the accident, the contamination in the other units was much higher than would otherwise have been the case. Immediate decontamination was necessary because the radiation levels due to contamination inside the units were measured as 100–600 mR/h, and the units had to be kept in a safe shutdown condition. Various decontamination methods were applied, including spraying with water and various decontamination solvents, steam ejection, dry methods using polymer covers, and the manual washing of surfaces. These methods were very successful, the contamination level having been reduced by a factor of 10 to 15, and the dose rate inside the buildings dropping to a measured range of 2–10 mR/h.

This publication has been superseded by INSAG-7

Since much decontamination of structures and surfaces in buildings will be necessary, the experience gained at Chernobyl will be extremely valuable for the nuclear community. This includes experience in decontamination methods, in minimizing radioactive waste and in control of the exposure of workers, and recommendations on the quality of surfaces to facilitate decontamination.

Before the decontamination of land and villages in the 30 km zone can begin, the destroyed Unit 4, which is still releasing several curies (of the order of 10^{11} Bq) of aerosols per day, has to be fully entombed. Furthermore, in those areas of the zone where the ground contamination is very high, the radionuclides should be fixed using polymer sprays or other fixation material to prevent resuspension. Methods are available for these two tasks and the work is in progress.

Tasks which have then to be performed are, for instance, the fixation of radionuclides in the soil to prevent their being taken up by plants, the removal of an upper layer of heavily contaminated earth and its disposal, the decontamination of forests or the fire protection of these forests so that they can act as long term accumulators of radioactive substances, and decontamination of water bodies, i.e. sediments and water plants. The aim is to allow the reuse of the land for agricultural purposes as soon as possible.

In addition to the aforementioned decontamination efforts, special agro-engineering techniques such as changes in the conventional systems of soil treatment, the use of special means to suppress dust, and the modification of harvesting and crop processing methods are required. Furthermore, some agricultural products will not, depending on their contamination levels, be directly used for human consumption, but will be stored and used for fodder, seed or industrial processing.

Problems which will be encountered in attempting the aforementioned tasks and for which, up until now, no well established solutions exist, include the following:

- Decontamination from very high levels of radioactive contamination of personnel, buildings, equipment and surrounding land, and associated control of worker exposure;
- Removal of large amounts of contaminated earth and its associated disposal;
- Removal or stabilization of contamination in forests;
- Decontamination of water bodies;
- Fixation of radionuclides in the soil using lime, mineral fertilizers and solvents.

In these fields there should be strong international co-operation, and all countries which have experience or will gain experience and which can contribute to solutions should be invited by the IAEA to participate.

5. TRANSPORT OF RADIONUCLIDES AND DOSES TO THE PUBLIC

5.1. Transport of radionuclides through the atmosphere and deposition on the ground

The release of radionuclides from the Chernobyl reactor began on 26 April and effectively ended on 6 May. The largest releases were on the first day and on 4 May and 5 May. In the first few days the wind blew towards the north and north-west. By 30 April the wind direction had changed giving rise to a plume of radioactive material moving to the south and east. There was no heavy rainfall at the reactor site or in Kiev over the period 26 April–30 May because rainclouds moving towards the area were dispersed (for example, by spraying silver iodide on them from aircraft).

The initial release, due to the explosions, consisted of all types of fission products, enriched in volatile elements such as caesium and iodine, together with noble gases. This material travelled to a height of about 1 km before horizontal transport began. Later releases consisted largely of volatile radionuclides, but there were some further releases of all types of fission products. These releases occurred at a much lower effective height.

The complex meteorological conditions, the artificial dispersion of rainclouds and the varying characteristics of the release led to a very complex pattern of atmospheric transport and deposition on the ground, both within the Soviet Union and in other countries. For the region of the Chernobyl site a detailed map of radionuclide deposition levels was built up by measuring external dose rates and by analysis of environmental samples (e.g. soil, grass). The pattern of deposition within other regions of the Soviet Union was established by taking gamma dose rate measurements from aircraft, and by analysing the radionuclide content of soil samples taken at a limited number of locations.

This procedure enabled an estimate of the total amounts of radionuclides deposited in the Soviet Union to be made with impressive speed, and this estimate was used in deriving the total quantity of radionuclides released. Some other countries have carried out similar exercises and eventually it will be possible to refine the initial estimate of the total release.

During and immediately after the Chernobyl accident, many measurements of dose rates and of radionuclide concentrations in air and on the ground were made in the Soviet Union and in other countries. These measurements, and supplementary information on meteorological conditions, can be used to establish an extensive database to be used to validate and improve models for predicting the atmospheric transport and deposition of radioactive materials. Discussions at the Post-Accident Review Meeting led to the conclusion that such a database should be established internationally, and that IAEA Member States should co-operate in model validation exercises concerned with dispersion and deposition over short, medium and long distances.

5.2. Radionuclide transfer through the environment and exposure of the public

5.2.1. Short term

During the period when the plumes of radioactive material were travelling through the atmosphere and radionuclides were being deposited on the ground, people living or working in the areas under the plumes received doses via direct external radiation from the plume, via inhalation of radionuclides and via external irradiation from deposited material. Deposited radionuclides, particularly I-131 and caesium isotopes, entered the terrestrial food-chains, and in the most affected areas some doses will have been received through consumption of contaminated milk, leaf vegetables and fruit before measures were introduced to restrict consumption of these products. In areas where the contamination levels were not so high as to require the introduction of bans on food consumption, doses will have been received via all these routes.

Initially, estimates of doses were needed in order to take decisions on counter-measures. These were obtained from environmental monitoring data, supplemented by predictive modelling where necessary. At a later stage measurements were made of I-131 in people's thyroids, particularly for children, and whole body measurements were carried out to determine levels of Cs-137. These direct measurements enabled better estimates to be made of the doses actually received.

The collective dose from external radiation to the 135 000 people who were evacuated was estimated to be 1.6×10^4 man·Sv. Most doses to individuals were less than 250 mSv, although some people in the most contaminated areas may have received doses as high as 300–400 mSv or more. Doses to the thyroids of individuals from inhalation (and possibly ingestion of contaminated foods) were estimated to be mostly below 300 mSv, although some children may have received thyroid doses as high as 2500 mSv. In other regions of the Soviet Union doses to individuals from external irradiation and from intake of iodine were very much lower.

5.2.2. Long term

Once the release of radionuclides has effectively ceased, and in subsequent months and years, the most important exposure pathways are external irradiation from deposited radionuclides (especially Cs-137, which has a radioactive half-life of 30 years), and internal irradiation from ingestion of contaminated food and water. Iodine-131, which has a radioactive half-life of eight days, was an important contributor to ingestion dose in the first weeks, but in the longer term Cs-137 tends to dominate, although other longer lived radionuclides (such as Sr-90 with a half-life of about 28 years) may also be important. There will also be a contribution to doses

from inhalation of radioactive materials which are resuspended into the air from the ground on which they were initially deposited.

Many measurements were made of radionuclide levels in the environment, both within the 30 km evacuation zone and in regions in the European part of the Soviet Union (i.e. the Ukraine, Byelorussia and the Russian Soviet Socialist Republic). In the case of the evacuation zone, the corresponding estimates of dose were used to determine whether, and if so when, people could return to the area. For the other regions, the purpose was to determine whether any further counter-measures were required, whether any could be lifted, and to estimate the radiological impact on the population.

Immediately after the accident, derived intervention levels were established for the concentration of I-131 in milk and milk products (cheese, cream and butter) and leaf vegetables. Methods of ensuring compliance with these levels were introduced and enforced. The levels were based on the principle that the dose to the thyroid of a child should not exceed 300 mSv per year. Standards were also introduced for the I-131 levels in meat, poultry, eggs and berries. At a later stage, when caesium and other longer lived isotopes became dominant, intervention levels of these radionuclides in a wide range of foods were established, based on the principle that the effective dose to an individual should not exceed 50 mSv in the first year.

From measurements of concentrations of actinides (particularly plutonium isotopes) in air in the 30 km zone, it became clear that under dry conditions and if winds were high, doses to individuals from resuspension could exceed the limits normally applied for members of the public in the Soviet Union. Accordingly, measures such as covering of 'hot spots' were taken to prevent resuspension.

Doses to individuals in various regions of the European part of the Soviet Union and doses to the whole population of these regions were calculated. Estimated individual doses from external irradiation in 1986 range from 0.03 mSv to 10 mSv. Committed doses from intakes of Cs-137 via foodstuffs were calculated to be of the order of 30 mSv for individuals in the Poles'ye region of Byelorussia and the Ukraine. However, measurements of caesium levels in people showed that 50% of them would receive a dose of about 3 mSv or less, and only 3% would receive a dose of 30 mSv or more. The reason for these differences lies in the pessimistic assumptions used in the dose calculations, particularly the assumptions about the transfer of caesium from the soil into plants, and the assumption that the individual consumes only food which is produced locally. Doses tended to be higher for people in rural areas because they spend more time outdoors and eat more locally produced food.

The collective dose to the population of the European Soviet Union from external irradiation over the next 50 years was calculated to be about 3×10^5 man·Sv. The collective dose to the same population from intakes of caesium in food over 70 years was estimated at 2×10^6 man·Sv. During discussion, many experts at the Review Meeting questioned this latter figure, because experience in estimating collective doses from releases of caesium to the atmosphere (e.g. from

This publication has been superseded by INSAG-7

nuclear weapons tests) suggests that the external dose is approximately equal to the dose via food consumption. It was made clear that pessimistic assumptions, of the type mentioned earlier, had been deliberately used in calculating the collective dose from food. More realistic assumptions could produce an estimate which is about a factor of ten lower (i.e. 2×10^5 man·Sv).

5.2.3. *Questions on environmental transfer*

Many questions on this topic consisted of requests for more detailed environmental monitoring data, either for the purpose of dose estimation or for validation of mathematical models to predict radionuclide transfer through the terrestrial environment, including the food-chains, through surface waters (both freshwater and marine), through groundwater and in urban environments. It was also clear that many countries had a vast amount of monitoring data which should be made generally available, in an agreed format. It was not possible to carry out this exchange of detailed information at the Review Meeting, and it was therefore recommended that further work be undertaken by the IAEA to establish mechanisms for such exchanges.

5.2.4. *Effects on ecosystems*

This subject was not discussed at the Review Meeting but it is addressed in the Working Documents produced by the USSR State Committee on the Utilization of Atomic Energy. From these it is evident that there will be visible effects on terrestrial and aquatic plant and animal life close to the Chernobyl reactor site. The Soviet Union intends to carry out long term, comprehensive radioecological studies in order to gain information about the effects of radiation, at high and low doses, on ecosystems.

6. HEALTH EFFECTS

The deleterious health effects that have been observed or can be expected in the future as a result of the Chernobyl reactor accident may be divided into two principal groups:

- (1) The early, acute effects, belonging to the group of so-called non-stochastic effects;
- (2) The late effects, mostly stochastic.

6.1. Early, acute effects

These effects have several features of which the most important ones are the following:

- (a) Pronounced threshold doses below which they do not occur;
- (b) Dependence on the dose rate, the response decreasing with protraction of the dose;
- (c) Early manifestation (within hours to weeks) of the signs and symptoms. With increasing dose the latency period before their appearance becomes generally shorter;
- (d) Specificity of the clinical picture as related to irradiation of specific organs;
- (e) Severity of clinical manifestations increasing steeply with increase of the dose above the threshold.

Several groups had been exposed to radiation at the Chernobyl power station to such an extent that resulting whole body doses produced various forms of acute radiation syndrome. In such cases the absorbed doses in the deeply situated organs of the body, e.g. bone marrow, alimentary tract, etc., were in the range from about 2 Gy up to about 16 Gy. The groups included operating personnel of the reactor and electricity generating plant, emergency squads and to the largest extent the fire brigades fighting the extensive early fires on the site.

From the data reported by the Soviet experts, several characteristics clearly emerge. Thus, acute radiation syndrome of varying clinical severity was diagnosed in 203 subjects. Although they were exposed to inhalation of radioactive aerosols containing fission and activation products, the levels of internal contamination were far below those that could significantly contribute to development of acute radiation syndrome. Only in two subjects with extensive thermal burns of the skin were high levels found (of the order of several tens and up to several hundreds of millions of becquerels of Cs-137 and I-131), but even this would not be considered of real clinical significance.

In conclusion, the acute radiation syndrome which developed in the 203 patients was due mostly to external irradiation with gamma and beta rays. A contribution from neutron exposure could be excluded on the basis of negative evidence obtained from measurements of Na-24 whole body activity in the patients, the radionuclide that is the principal activation product after fast neutron irradiation of the human body.

Effects of external irradiation can be separated into those due to penetrating gamma rays and to relatively non-penetrating beta particles.

The observed signs and symptoms of acute bone marrow failure and of the intestinal syndrome were due to gamma irradiation. The estimated doses ranged from about 2 Gy up to 16 Gy with reversible marrow depression towards the lower and

This publication has been superseded by INSAG-7

irreversible at the upper end of the range. Severe intestinal syndrome was observed above 8–10 Gy.

The external beta irradiation, partially from aerosols deposited on the surface of the skin and clothes, led to the development of severe skin burns in 48 persons, covering in some cases up to 90% of the body surface. These burns, which were very difficult to treat, proved to be a major complicating factor and affected prognosis and the final outcome of the disease in numerous cases. In most cases of acute radiation syndrome with lethal outcomes (29 cases up to the end of July 1986) the burns had a strong effect on the ultimate fates of the victims. In view of this observation it is essential to consider the application (and possible development) of technical means that could prevent the occurrence of serious skin burns in the future, in the event of the experience of a similar drastic accident.

Selection from among heavily exposed persons requiring hospitalization and specialized treatment was very fast (within 4–12 hours of the accident) and was based on the severity and rapidity with which the initial symptoms and signs of acute radiation syndrome occurred. From the analytical side the early diagnosis was based on observation of the lymphocyte count in the peripheral blood. Full clinical verification demonstrated later that this was a very efficient and adequate way of initial identification of subjects with acute radiation syndrome of clinical significance.

With regard to bone marrow insufficiency, the specialized treatment of the radiation syndrome was essentially based on substitutive and supportive measures. Transfusion of platelets prevented the occurrence of serious haemorrhagic signs and complications, as did the blood transfusions with regard to ensuing anaemias. Chemotherapy and various antibiotics were applied to combat bacterial infection and septicaemia, and in severe cases the infusion of concentrated gamma globulin proved relatively effective. Viral infections of the herpes type with dermal manifestation were combated with an appropriate antiviral drug (Acyclovir).

Treatment of the intestinal radiation syndrome was based primarily on artificial intravenous feeding and combating the systemic loss of fluids and essential ions, and on intensive measures to prevent bacteraemia and septicaemia of intestinal origin. Special antiseptic regimes in normal hospital wards were instituted and Soviet experts provided evidence of their effectiveness both in terms of the very low concentrations of bacteria in the air of the wards and in terms of the successful treatment of the severe sickness in numerous cases. In general it appears that the applied treatment was effective within the limits imposed by the severity of acute radiation syndrome, and this may be judged from the therapeutic results in dose ranges where otherwise a lethality substantially higher than that observed would be expected.

Bone marrow transplantation was applied in 13 cases with doses above 6 Gy in which irreversible bone marrow depression was expected. All but one of these patients died and the conclusions reached by Soviet experts was that the effectiveness of the procedure can be postulated only for a narrow range of doses, and that even then, aside from the possible lack of positive influence on the conditions of patients,

This publication has been superseded by INSAG-7

negative, deleterious effects have to be taken into account, as was demonstrated in several cases.

As has already been said, particularly intensive therapy was required for dealing with the skin burns; this remained ineffective, however, in cases of very extensive involvement of the teguments, which determined the fatal outcome.

The therapy of bone marrow depression and intestinal involvement was supported by assessment of the whole body dose by means of so-called biological dosimetry. The method used was that of analysing the frequency of chromosomal aberrations (dicentric) in peripheral blood lymphocytes. In the situation considered, the use of this method was particularly indicated, owing to the rather uniform irradiation of the body. However, one has to remember that the method is very laborious and yields results not earlier than 48-55 hours after the withdrawal of blood for lymphocyte culture. In this context, measures (equipment, training) to accelerate the scoring of aberrations (automation of metaphase finding, computer assisted evaluation of metaphase figures) should become more widely available. Other, faster and easier, methods should also be contemplated and developed for the purpose of biological dosimetry if possible.

The prognostic value of the determination of the blood levels (activity) of several enzymes was clearly demonstrated.

It appears that experience in the treatment of acute radiation syndrome and of skin burns induced by massive beta irradiation should become widely available after the final elaboration and analysis of the immense amount of data collected. The results should help in arriving at the optimal therapeutic schemes available at the current state of medical knowledge, and the experience referred to seems to contain numerous indications for the successful handling of a major emergency of a similar nature, should this be required in the future.

It appears essential to stress the fact that the degree of success in the medical handling of patients with acute radiation syndrome depended critically on the availability of a centre, in Moscow, highly specialized in the diagnosis and treatment of the sickness. The experience gathered there in preceding years in treatment of individual accidental cases and of patients irradiated for medical reasons proved to be of immense value as it resulted in the availability of the specialized personnel, facilities and techniques. This appears to be one of the principal medical lessons of the Chernobyl accident.

Doses incurred by the population evacuated from the 30 km zone around the Chernobyl power station did not reach the threshold level for clinically manifest signs of acute radiation syndrome. It must be stressed that not a single case was diagnosed from among the 135 000 evacuees. They were promptly examined after the accident, employing mobilized teams of physicians, medical assistants, medical students and nurses with appropriate medical analytical facilities. From the reports submitted by the Soviet experts it appears that effective centralized organization of

This publication has been superseded by INSAG-7

the medical handling of the emergency was a prerequisite for the success of the operation.

Potassium iodide tablets were distributed for preventing the accumulation of radionuclides of iodine in the thyroid glands of members of the public. From the evidence presented there is no reason to question the effectiveness of this preventive measure. Thousands of measurements of I-131 activity in the thyroids of the exposed population suggest that the observed levels were lower than those that would have been expected had this prophylactic measure not been taken.

It is important to note that no immediate serious side effects of potassium iodide were observed and in not a single case were there indications for hospitalization due to its administration. The period of observation was too short to provide any data on the frequency of possible induction of thyreotoxicosis by this prophylactic procedure.

6.2. Late effects

In contrast to the early non-stochastic effects, the late stochastic effects do not manifest a dependence of their severity on the radiation dose, and only the probability of their occurrence increases with the dose. For most stochastic effects (cancers, genetic mutations) the lack of a threshold dose is commonly postulated. Each increment of dose therefore carries an additional probability of the induction of cancers and mutations. The likelihood of manifestation of these effects depends on numerous factors, among which the age at irradiation is of prime importance. For cancers, the chances of expression increase with the remaining lifespan, and for genetic effects the probability of childbearing is directly relevant.

It has to be stressed that these effects are non-specific in their clinical and histological appearance and on a case-by-case basis cannot be distinguished from those that occur naturally. The induction of stochastic effects can be demonstrated only by applying epidemiological methods.

A complete assessment of the detriment due to cancer induction by the irradiation of human populations as a result of the Chernobyl accident cannot be made with sufficient confidence at present. The estimates of doses, individual, mean and collective, to the population of the Soviet Union are preliminary and to some extent incomplete, and may change in the future as a result of more detailed and thorough evaluation.

Assessment of the risk (probability of occurrence) of specific cancer forms cannot be attempted owing to the lack of information on mean doses in individual organs.

The data for communities outside the Soviet Union are also being collected and evaluated, and it will take an appreciable time to arrive at estimates of the collective doses for many countries that would permit the evaluation of the health effects on a global scale.

This publication has been superseded by INSAG-7

However, an appropriate and tentative estimate of the number of fatal cancer cases can be made on the basis of collective dose estimates derived so far for parts of the Soviet Union and presented at the Review Meeting. Under the assumption of a no-threshold linear dose–response relationship, the estimate would be equal to the product of the risk coefficient (10^{-2} Sv^{-1}) and the collective dose. The risk coefficient generally used of the order of 10^{-2} Sv^{-1} is considered in radiation protection to apply to the age distribution of workers. Nevertheless, it is considered that the uncertainties involved do not justify the application of a different coefficient for the special age distribution in the general public.

The aforementioned uncertainties, and the fact that the coefficient was derived from epidemiological observations at the higher doses for the specific purpose of planning protection, make it obvious that the use of the same coefficient for assessing consequences in a given exposure situation is to some extent speculative.

The value of the collective dose due to external irradiation of the 135 000 evacuees was estimated at $1.6 \times 10^4 \text{ man}\cdot\text{Sv}$, and therefore the number of all radiation induced cancers in this group should equal about 160. The contribution of doses to the thyroid from I-131 (with appropriate weighting) to the eventual collective effective dose equivalent would increase this estimate. For instance, if an average dose to the gland was 300 mSv, the collective dose to the thyroid would be of the order of $4 \times 10^5 \text{ man}\cdot\text{Sv}$, and its contribution to the effective dose equivalent would amount to $1.2 \times 10^3 \text{ man}\cdot\text{Sv}$, adding some ten cases of fatal thyroid cancer (plus a substantially larger number of non-fatal cases). In this group the relative contribution of dose from Cs-137 (from ingestion) would be marginal.

To put these rough estimates into perspective it has to be remembered that over 70 years about 20% of those who were evacuated would normally die of cancer, i.e. about 27 000. The estimated 170 additional cancers would constitute about 0.6% of the so-called spontaneous cases. For that part of the population of the European Soviet Union to which the collective dose estimate applies (75 million people), a similar calculation yields a relative increase in the cancer mortality due to external irradiation and internal exposure from Cs-137 that would be within 0.03–0.15% of the natural value. Similarly, the possible increase over the spontaneous mortality from thyroid cancer was estimated at about 1%.

As these values constitute a very small fraction of the spontaneous incidence (and mortality), the chances of epidemiological detection of these effects are negligible. Only in the cohort with mean doses substantially above 0.1 Gy could some effects possibly be discovered (e.g. leukaemias or benign and malignant thyroid neoplasms).

The magnitude of the genetic consequences, in terms of the number of mutations induced, can be approximately estimated from the information accumulated so far by UNSCEAR and the ICRP. It appears very unlikely that in the first two generations the detriment involved could exceed a small fraction (20–40%) of that expected due to possible cancer induction.

This publication has been superseded by INSAG-7

Irradiation in utero in the period from 8 to about 15 weeks after conception carries a risk of severe mental retardation, and also of diminished mental performance in the less affected children. The risk of severe mental retardation was estimated at about 40% per sievert after acute, instantaneous irradiation, with the possibility of a non-threshold linear type dose-response relationship. In order to estimate possible effects of this type, knowledge would be necessary of the number of women in that period of pregnancy, of the doses to which they were exposed and of the fraction of pregnancies that would result in live born children. This information is not available. Another source of uncertainty in such an estimate would derive from the lack of any information about possible effects of the dose rate upon the magnitude of the response (the irradiation of the population within the 30 km zone was at a much lower rate than that from which the original data on mental retardation were derived).

Section V

SAFETY ISSUES TO BE PURSUED

The nuclear community wishes to derive whatever safety lessons can be learned from the Chernobyl accident. Although much information was gained during the Post-Accident Review Meeting, supplementary discussion in some areas is needed to assess the safety significance of several issues. The list of topics given below is only a tentative one, since international analysis of the event is only beginning. Hence, the list will have to be periodically updated to account for new information exchange between the Soviet Union and other countries, new issues raised by theoretical and experimental studies under way or to be undertaken in the future, and the issues that are resolved.

Issue No. 1. ASSESSMENT OF SAFETY PROCEDURES

Since the immediate cause of the accident was successive violations of operating rules, disabling safety systems, it is necessary to understand how such violations were possible in practice. This requires an understanding of the existing plant procedures, organization and responsibilities, as well as the means used to violate the rules, especially the bypassing of safety systems. Discussion of this issue might lead to exchange of information on the various methods used:

- (a) For the establishment and testing of procedures; and
- (b) For enlisting the plant operator's support for established procedures.

These experiences would be useful for all of us in understanding the human need for positive reinforcement of good performance in addition to the acknowledged need for a disciplinary regime. In each national culture the most successful methods might be quite different from the general norms.

Issue No. 2. OPERATIONAL ANALYSIS OF THE ACCIDENT SEQUENCE

The Soviet experts presented the results of a simulation made using a mathematical model which took into account the actual state of the plant and the corresponding values of the relevant physical parameters. This simulation shows that the operator's actions led to a reactivity excursion. Many such simulations, with different input data for the plant parameters and with operator's actions different in time or in nature, would give great insight into, for instance, what might have happened if the operator had become aware of the hazardous state of the reactor and an order to shut down had been given immediately. This would help to understand

This publication has been superseded by INSAG-7

the relative safety significance of the various actions of the operator and the responses of the reactor to them.

Discussion of this issue might lead to an exchange of equivalent simulations on all operating and future nuclear power plants; such simulations could be prepared by responsible national authorities and distributed through the IAEA or other channels.

Issue No. 3. FEASIBILITY OF CONTAINING THE CONSEQUENCES OF SUCH AN ACCIDENT

The defence in depth safety concept implies that one considers the possible failure of the systems provided for accident prevention and tries to rely on one, or several, ultimate barriers to ensure a minimum release of radioactive material from the containment. INSAG's brief evaluation of the mechanical energy developed in the Chernobyl event and our understanding of various relevant effects are much too limited to determine whether a structure adequate to contain such an event is feasible for all existing and future nuclear power plants. It may be, as the Soviet experts believe, that no containment building could have withstood the mechanical effects of such an accident.

To evaluate this issue, experimental research may be necessary to better describe the physical phenomena which occurred during the first two to three seconds of the accident, such as fuel fragmentation, fuel-coolant interaction and steam explosion, and to explain the second explosion. However, a preliminary analyses could be done by a panel of experts using data already in the literature. Similar analyses on other plant types might be available for exchange.

Issue No. 4. MAN-MACHINE INTERFACE IN DIAGNOSING INCIPIENT ACCIDENTS

A key lesson learned from the review of the Three Mile Island accident is that the operators should have immediately available to them, in a clear and unambiguous way, the information that can tell them that the safety of the plant is seriously threatened. The best example is the display of the 'saturation temperature margin', which gives the operator immediately useful information on the status of core cooling.

In the light of the Chernobyl accident, it appears vital in preventing reactivity initiated accidents that operators know the operational reactivity margin, or excess reactivity, expressed in familiar terms. To analyse this situation, a more detailed description of the present systems, including both the way this parameter is calculated and the manner of its display to the operator, would be useful.

This publication has been superseded by INSAG-7

This analysis could be extended to other important parameters, such as the saturation temperature margin at the inlet of the core, and could be the basis of a more general assessment of the requirements for a display panel providing a minimum of safety parameters. Such an analysis of the Chernobyl event might possibly result in verification of the lessons already learned from the Three Mile Island accident. The issue is sufficiently important to safe operation that it should be discussed by interested parties led by experienced senior operating staff. Existing information might be exchanged first, then residual tasks could be identified.

Issue No. 5. IMPROVING SCIENTIFIC KNOWLEDGE FOR EVALUATING 'SOURCE TERMS'

The Chernobyl accident provides a most important source of data on radioactive release mechanisms. While the mechanisms that played a role in the Chernobyl release may not be entirely relevant to estimating potential releases from other reactor types, it seems clear there would be a general benefit for safety in deriving as much information as possible on what took place in the Chernobyl reactor between 26 April and 6 May.

During the Post-Accident Review Meeting, many participants asked detailed questions on physical and chemical forms of radionuclides, proposed certain measurements to obtain additional useful data, suggested possible release mechanisms, etc. When Soviet scientists have communicated their available data and have received data in exchange from others, a specialists' meeting could be organized to screen the data and outline an international research programme if such is required. The results of this discussion might be used to enlighten the INSAG study of the 'source term'.

Issue No. 6. ACCIDENT MANAGEMENT ON-SITE

Operation and management of multiunit sites such as Chernobyl (four units in operation, two under construction) raises a large number of important issues such as interunit ties, arrangements for operation of the non-damaged units, the degree to which operators of non-damaged units can come to the assistance of operators involved in test or accident management procedures, etc. For example, Unit 3 might have continued operation until the fire on Unit 4 was out because of some general or specific need for electric power, water, or other services to aid the Unit 4 fire-fighters.

Following discussions, it might be found useful to convene a specialists' meeting of those who operate multiunit sites, including an exchange of information concerning policies and procedures.

Issue No. 7. OPERATIONAL SAFETY EXPERIENCE

The Soviet experts stated during the Meeting that, in the 100 reactor-years of experience with RBMK type reactors, there had been no abnormal occurrence that could be considered a 'precursor' for the 26 April accident. However, the Soviet interpretation of 'precursor' may be different from that used elsewhere. Whereas there has been no previous series of events like those which led to the accident, the events at the Kursk station described in Section 2.12.2 of Annex 2 of the Soviet report would be extremely interesting for examining some of the important transient characteristics of the Chernobyl station.

Extension and continuance of the existing IAEA Incident Reporting System may be the most effective means of dealing with this issue.

Using the Chernobyl experience simply as an example, it would be useful for others to know of operator errors like those which led to the power decrease to 30 MW(th), or, more generally, of unexpected transients where the values of the various reactivity coefficients played a role. If Soviet reanalysis of its RBMK operating experience were to identify relevant events, that information might be useful in analysing the Chernobyl accident, and information on the observed frequency of various types of deviations would help in assessing their safety significance.

Issue No. 8. ON-SITE DECONTAMINATION

Clearly, there is great interest in the technical community in receiving whatever information Soviet experts can provide on the methods used to reduce radioactivity on the site, both inside and outside the buildings. Such information could provide the basis for the development and publication of a guide for operators who may have to face a contamination situation.

Issue No. 9. MODELS FOR PREDICTING RADIOACTIVE DISPERSION

A clear lesson from this accident is that it should be assured that senior nuclear power plant staff can correctly estimate the dispersion of radionuclides in the environment under various accident conditions. Obviously, the Chernobyl event constitutes a unique source of information on radioactivity dispersion. Despite uncertainties in the magnitude of releases and the lack of detailed data which may make meteorological interpretation difficult, a comprehensive analysis might be established and pursued with determination by the responsible technical authorities in the Soviet Union, assisted as necessary by experts from other countries. Information exchange programmes should be conducted under the auspices of the IAEA.

This publication has been superseded by INSAG-7

Issue No. 10. RADIATION PROTECTION

It is important to assess the environmental effects of the radioactivity released, the effectiveness of the countermeasures and medical treatment of highly irradiated personnel and the long term consequences for surrounding populations, since the results will be very important for emergency measures.

This publication has been superseded by INSAG-7

Section VI

GENERAL OBSERVATIONS AND PROVISIONAL CONCLUSIONS

At the Post-Accident Review Meeting, Soviet scientists and engineers presented a two-part report which includes basic technical information on the Chernobyl nuclear power station, the operational sequence leading up to the accident, its probable causes, the evaluation of the accident, radiological releases, consequences of the accident, and the countermeasures taken both on-site and off-site. Soviet experts also reported on their scientific research on technical, medical and environmental issues of the accident.

The Soviet report was thorough and professional. The frank and open presentations by the Soviet participants in the Meeting were well received by other participants, who responded to the Soviet experts with hundreds of written questions.

Most of these questions were requests for further details and quantitative answers on technical issues which would require further investigation and examination. Undoubtedly additional and firmer details are expected over the coming months and years.

INSAG has reviewed the report made to the Post-Accident Review Meeting by the Soviet experts, and INSAG members have had further discussions with the Soviet experts. The INSAG view is that the course of events described as having taken place is entirely plausible, and it is consistent with the understanding of how such systems might be expected to behave under the factual conditions described. This is not to say that questions do not remain, and the Soviet experts are among the first to agree with this conclusion.

There was a common understanding on the need to strengthen international co-operation on nuclear safety and radiological protection. It is believed that the discussions that took place may help Soviet experts to benefit in their planning of the necessary research programme.

Although it would be incorrect to state at this time that final comprehensive conclusions can be drawn on the causes, consequences and implications of the accident, an overall picture did emerge at the Post-Accident Review Meeting, and we can identify a number of lessons.

For example, the Soviet experts recognized the benefit to be gained from modifications to the RBMK type reactors, and reported that they have already taken action to increase the number of emergency protection rods and to lay down a requirement for a minimum insertion position for all the control rods.

These modifications are intended, in combination with improved administrative procedures, to make it much more difficult to reach operating conditions that could result in a fast reactivity excursion resulting from any cause, including a severe violation of operating procedures.

This publication has been superseded by INSAG-7

Although not in a position to confirm that these modifications alone could ensure that the safety goal would be met, INSAG strongly endorses this goal which has been adopted by the Soviet authorities for the RBMK reactors.

The proceedings of the Review Meeting and the findings by the INSAG members, IAEA experts and other participants have led to the following provisional conclusions, which are grouped into the categories of nuclear safety, radiation protection and summary conclusions.

In addition, other, more specific conclusions are to be found interspersed in the full text of the report. These conclusions are not repeated here.

A. NUCLEAR SAFETY

1. NO NEW PHYSICAL PHENOMENA HAVE BEEN IDENTIFIED

No physical phenomena can be identified which have not been previously identified in safety analyses and the subject of some theoretical and/or experimental research.

Nevertheless, all nuclear power plant operators should feel the importance of reviewing their existing safety analyses to conduct specific risk studies, to verify that all the safety issues which have been identified in the past are still properly being taken care of.

2. THERE IS A NEED FOR A 'NUCLEAR SAFETY CULTURE' IN ALL OPERATING NUCLEAR POWER PLANTS

The root cause of the Chernobyl accident, it is concluded, is to be found in the so-called human element. The lessons learned from this imply three lines of action:

- (1) Training, with special emphasis on the need to acquire a good understanding of the reactor and its operation, and with the use of simulators giving a realistic representation of severe accident sequences;
- (2) Auditing, both internal and external to the utility, in particular to prevent complacency arising from routine operation;
- (3) A permanent awareness by all personnel of the potential safety implications of any deviation from the procedures.

These lessons drawn from the Chernobyl accident are valuable for all reactor types.

This publication has been superseded by INSAG-7

The vital conclusion drawn is the importance of placing complete authority and responsibility for the safety of the plant on a senior member of the operational staff of the plant. Formal procedures properly reviewed and approved must be supplemented by the creation and maintenance of a 'nuclear safety culture'. This is a reinforcement process which should be used in conjunction with the necessary disciplinary measures.

3. THE DEFENCE IN DEPTH CONCEPT MUST REALLY BE IMPLEMENTED IN REACTOR DESIGN

Schematically, three levels can be identified.

At the first level, one should look for inherent stability. At equilibrium fuel irradiation, the RBMK reactor has a positive void reactivity coefficient. However, the fuel temperature coefficient is negative and the net effect of a power change depends upon the power level. Under normal operating conditions the net effect (power coefficient) is negative at full power and becomes positive below approximately 20% of full power. The operation of the reactor below 700 MW(th) is restricted by operating procedures owing to the problems associated with maintaining the thermal-hydraulic parameters in their normal operating range.

At the second level, automatic safety systems must act as soon as the safety of the plant is seriously threatened. This requirement applies to all reactor types. This was not the case for the shutdown system on the Chernobyl reactor at the time of the accident.

Finally, the last level relates to the ultimate passive barrier which should be able to contain most of the radionuclides if the first two lines of defence have failed. The purpose of the containment building for those reactors that have this protection is well understood.

However, we must also recognize that this ultimate protection may not be technically feasible in every case, and it is not clear today that such a containment could have been designed to protect against the consequences of the reactivity excursion which occurred at Chernobyl. The question must nevertheless be raised, and if there is no feasible solution, special attention should be given to guaranteeing a low probability of occurrence of a similar accident in the future.

4. THE IMPORTANCE OF A SATISFACTORY MAN-MACHINE INTERFACE IS RE-EMPHASIZED

It will never be possible to guarantee that there will be no operator error, and that a design is totally foolproof. It must therefore be recognized that there could be events when an appropriate operator action would be necessary to prevent a severe

This publication has been superseded by INSAG-7

accident. Past experience has shown that human intervention can be very effective if there is a thorough understanding of the situation in the plant. This is why an appropriate man-machine interface is important for safety, not only to prevent operator errors, but also to cope with unforeseen accidents for which the design may not be entirely adequate.

From the Chernobyl accident, and in accordance with the lessons learned from Three Mile Island, two lines of action can be identified:

- (1) The clear display to the operators of data vital to safety should be tailored to ensure their optimum use of it. For a system as complex as a nuclear power plant, real-time data display and interpretation are important. Built-in diagnostic capability should be included.
- (2) Although ultimate reliance must rest on the operating staff and their comprehension of the system safety, the complexity of the nuclear power plant always requires that there be reliable safety backup by way of automatic devices that ensure that the plant remains in safe operating territory in all respects. This backup must be rapid by way of its logical structure and speed of response. It must be so designed as to be difficult to bypass, and so that normal or planned operation raises no temptation to bypass it.

B. RADIATION PROTECTION

1. EARLY RESPONSE

- (1) Immediately after the alert reached Moscow, a specialist team was dispatched to the site to assist local authorities and plant management. A centralized emergency centre with all the authority and the powers to direct the response organization was established. The prime observation from all of this is that the rapid centralization of authority for emergency operations was very effective in organizing and co-ordinating all necessary actions. This is probably essential to success in any such emergency.
- (2) With regard to decontamination and accident recovery work performed immediately after the accident at Chernobyl, the scope and scale of the effort were far beyond those ever before experienced at a nuclear power plant site. It is observed that all other people who are responsible for this type of work should study this case and learn from it.
- (3) Fighting fires at a nuclear power plant with an additional large scale radiological hazard was an entirely new experience. The types of procedures, equipment and protective clothing used in this event should be examined carefully by all those responsible for such emergency responses.

This publication has been superseded by INSAG-7

- (4) Medical treatment of acute radiation syndrome was effective within the limits imposed by the doses incurred. Severe skin burns induced by beta radiation added significantly to the difficulties of supportive and substantive treatment of the syndrome, and also affected to a significant degree the fatal outcome of the disease in 29 victims. Technical measures should be taken to prevent the occurrence of extensive skin burns should an accident of a similar nature occur in the future. Bone marrow transplants performed in selected cases did not appear to offer real therapeutic advantages in this group. Internal contamination was inconsequential in the induction of acute radiation sickness. This experience should be carefully considered by the medical community.
- (5) Enormous problems arose in connection with the evacuation, such as in relocating people and cattle, in monitoring medical and social assistance, and in transportation and logistics. As already mentioned, the centralization of authority and powers was of primary importance in organizing and coordinating all necessary actions. A total of 135 000 people were evacuated from a zone of radius about 30 km around the plant. No individual of these had to be hospitalized as a result of radiation injuries.

2. RADIONUCLIDE RELEASE

The Soviet experts estimated that 100% of the noble gas radionuclides escaped the plant. Of the remaining, condensable, radionuclides, the release amounted to about 1×10^{18} to 2×10^{18} Bq (3×10^7 to 5×10^7 Ci)⁵ or about 3–4% of the core inventory of radioactivity. Further characterizations of the physical and chemical nature of the radionuclide release are being undertaken by Soviet experts. Chemical forms of the material and the particle size distribution of aerosols are being determined.

Continued interactions with the Soviet experts as this work progresses will be valuable to all reactor safety programmes.

3. RADIONUCLIDE TRANSFER AND EXPOSURE OF MEMBERS OF THE PUBLIC

This accident differed from those which are usually considered in radiological assessments of hypothetical accident releases from nuclear power plants in that the release was prolonged, it varied in rate and radionuclide composition over time, and the meteorological conditions were complex. These characteristics led to a very com-

⁵ Radioactive releases and activities are corrected to 6 May 1986.

This publication has been superseded by INSAG-7

plex pattern of atmospheric deposition on the ground, both within the Soviet Union and in other countries. The pattern of deposition was established very quickly through environmental monitoring. Deposited radionuclides, particularly I-131 and caesium isotopes, entered the terrestrial food-chains. Bans on the consumption of various foods were introduced and enforced, and measures were taken in the Soviet Union to provide supplies of uncontaminated drinking water where necessary.

The radionuclide which contributed most to the collective dose (i.e. the total dose to the population of the Soviet Union), and to the dose to the whole body of individuals, was Cs-137. The collective dose to the population of the European Soviet Union over the next 50-70 years is estimated to be of the order of 2×10^6 man·Sv, with most individuals receiving a dose over their lifetime which is less than that from natural background radiation. Iodine-131 gave rise to comparatively high doses to the thyroids of some individuals in the short term, but in the long term it is not an important contributor to the total dose either for individuals or for the whole population.

4. LATE STOCHASTIC HEALTH EFFECTS

The magnitude of the health impact of the late stochastic effects, mostly neoplastic and genetic in nature, can be assessed only after evaluation of the resulting collective doses. The information in this regard from the Soviet Union is preliminary and tentative. From the information available it appears that over the next 70 years, among the 135 000 evacuees, the spontaneous incidence of all cancers would not be likely to be increased by more than about 0.6%. The corresponding figure for the remaining population in most regions of the European part of the Soviet Union is not expected to exceed 0.15% but is likely to be lower, of the order of 0.03%. The relative increase in the mortality due to thyroid cancer could reach 1%.

The number of cases of impairment of health due to genetic effects, may be judged not to exceed 20-40% of the excess cancer cases. There is no information at present on which possible consequences of the in utero irradiation of human foetuses within the 30 km zone could be assessed.

Data on collective doses from other countries are in the process of evaluation, and the assessment of possible stochastic consequences must be deferred to a time when these data become available.

Preliminary estimates have been made of the doses to individual members of the public in the Soviet Union and of the dose to the population as a whole. These estimates will be refined as more data become available, and the overall radiological consequences of the accident will be assessed by UNSCEAR, in co-operation with the IAEA and WHO, on the basis of data collected from member states. International discussions should be held about the methodology for an epidemiological study of workers and selected groups of the population in the region of the plant.

5. DECONTAMINATION

Long term protective measures on the plant and in its environment are necessary. Problems which will be encountered in attempting to decontaminate these areas are the safe disposal of large amounts of contaminated earth, the removal of a layer of earth and the associated control of doses to the workers, the fixation of radionuclides in the soil, and finding methods to decontaminate forests and water bodies. Experience in this field is of great importance and international exchange of the experience is very much desired.

C. SUMMARY CONCLUSIONS

INSAG concludes that a major event in the class of events termed core disruptive accidents (CDAs) occurred at Chernobyl. An opportunity now exists for the world's safety experts to learn from this tragic event in order greatly to improve our understanding of nuclear safety. This accident is almost a 'worst case' in terms of the risks of nuclear energy. It is to be emphasized that, even under these circumstances, no member of the public had to be hospitalized as a result of radiation injuries. The victims were 300 power plant and fire-fighting personnel admitted to hospitals, of whom 31 have so far died.

INSAG studied the reasons for and the consequences of the Chernobyl accident to the extent possible at present. INSAG remains convinced that if available safety principles and knowledge are effectively deployed, nuclear power at its present status is an acceptable and beneficial source of energy. Although the accident that happened was dramatic and had far-reaching consequences, it did not exceed in scale disasters of other types that continue to occur, natural and man made. However, there is potential for improvements in the design and operation of nuclear power plants.

At this Meeting the Soviet experts explained different modifications to the RBMK type reactor. These are intended, in combination with improved administrative procedures, to make it much more difficult to reach operating conditions that could result in a fast reactivity excursion from any cause, including severe violation of operating procedures. The brief study reported here cannot provide full confirmation that the intent has been achieved by these modifications. However, INSAG strongly endorses this goal which has been adopted by the Soviet authorities for the RBMK system.

Regular worldwide communication in safety related areas could greatly simplify meetings such as this one. Such an understanding, previously established, would have increased the value of the Post-Accident Review Meeting to those present and to all Member States. One need not learn from serious accidents alone; understanding small disruptions is preferable. Prevention is the key.

This publication has been superseded by INSAG-7

Section VII

RECOMMENDATIONS

A. NUCLEAR SAFETY

1. FOLLOW-UP ACTIVITIES

Evaluation and analysis of the complex physical and chemical phenomena of the Chernobyl accident sequence and consequences are in their early stages. Further work is necessary in order to allow a more consistent evaluation of the simulation of the accident. The IAEA should promote international co-operation to achieve this objective. It should make the necessary arrangements to do so. It should disseminate the corresponding technical information and facilitate the interchange of analytical methods and the results of the analyses. INSAG wishes to be kept informed of the progress of these activities.

2. FURTHER IAEA AND OTHER INTERNATIONAL ACTIVITIES

- (1) The IAEA should promote and, where appropriate, co-ordinate analyses of severe accidents for all reactor types and facilitate the flow of the necessary information.
- (2) The IAEA should strengthen its work in promoting, assisting and facilitating the use of probabilistic safety assessment (PSA), by reviewing the techniques developed in Member States for the use of PSA, assisting in the formulation of guidelines for its use and helping Member States to apply such guidelines in order to enhance safety in all nuclear power plant operating modes.
- (3) The IAEA should devote special effort to promoting exchanges of experience, developing additional guidelines — in particular relating to the prevention of severe accidents — and giving assistance in the field of operator qualification, education and training so as to create a 'nuclear safety culture' in nuclear power plant operation. The feasibility of voluntary international accreditation of operator training programmes should be considered.
- (4) The IAEA should increase its efforts to promote exchanges of experience concerning the man-machine interface, with particular emphasis on the balance between automation and direct human action and on the need for additional operator aids in the nuclear power plant control room. Exchanges should include, in particular, the experience of nuclear power plant operators, and the IAEA should co-operate with international organizations representing such operators.

This publication has been superseded by INSAG-7

- (5) The IAEA should organize a programme of work including an international topical meeting on 'Quality Assurance Activities in Nuclear Power Plant Operation' with particular emphasis on control room procedures. The topic includes detailed prescription of procedures, required verification, shift turnover, confirmation of follow-up actions and notifications to proper authorities.
- (6) The Secretariat should provide INSAG with the support necessary to formulate in a self-supporting document the basic safety principles for existing and future reactor types, with special attention given to those principles which emerge from post-accident analyses. These principles should be common to all reactor types, even if some accommodation to specific design concepts is needed.
- (7) Existing international standards (NUSS) should be reviewed in order to ensure the incorporation of the lessons learned from accidents regarding important matters such as reactivity initiated accidents and fire prevention and fire-fighting.
- (8) Member States may consider strengthening their co-operation with the IAEA through the voluntary invitation of OSART missions and the provision of experts for such missions. The IAEA should enhance its capability to provide OSART services.
- (9) The IAEA's Incident Reporting System (IRS) should be upgraded and expanded so as to broaden the information input base, and the information provided to the IRS should be analysed more extensively with a view to learning lessons which can be made available to Member States.
- (10) The IAEA should organize a conference on 'The Interaction between Reactor Design and the Operator', with particular emphasis on design features which can assist operators in carrying out their safety responsibilities and which provide automatic protective action when operator actions put the plant into a potentially unsafe state.
- (11) Member States, through the activities of regulatory authorities, should arrange for reviewing procedures for the safe operation of nuclear power plant during non-routine tests. This procedure also should be included in the NUSS programme.
- (12) The IAEA should organize a symposium on fire protection covering:
 - (a) The development of the scientific and technical bases for fire prevention and fire-fighting techniques, account being taken of severe conditions such as high temperatures and of the nuclear materials present;
 - (b) Improvements in fire prevention and fire-fighting equipment for nuclear power plants.

It is expected that the results of the symposium would serve as input in developing possible new standards for fire prevention and fire-fighting (see point (7)).

B. RADIATION PROTECTION

1. FOLLOW-UP ACTIVITIES

- (1) The IAEA should take the lead in evaluating the considerable experience gained through accidents in the assessment, prognosis and treatment of non-stochastic effects in highly exposed persons — particularly acute radiation syndrome and radiation induced skin lesions. Also, guidance should be developed for the establishment of basic therapeutic schemes and the formulation of correct prognoses.
- (2) The IAEA should, in collaboration with other international organizations, arrange for an exchange of experience of past epidemiological studies with a view to determining the usefulness of their results for the development of a methodology (including procedures for the establishment of a database and of registers of individuals) for an epidemiological study of the late effects in selected groups exposed in the Chernobyl accident.
- (3) The IAEA should, together with other international organizations, co-operate in the assessment of the individual doses and the collective dose resulting from the accident, planned by UNSCEAR as a part of its continuing assessment of the impact of all radiation sources.
- (4) The IAEA should examine the experience gained in sheltering and evacuating the public after the Chernobyl accident with a view to determining the effectiveness of such protective measures, the problems associated with their introduction and their applicability as a function of time and environmental contamination levels.

2. FURTHER IAEA AND OTHER INTERNATIONAL ACTIVITIES

- (1) Given the fact that the lack of internationally recommended values for the dose per unit intake (by inhalation or ingestion) of radionuclides as a function of the age of the individual and as a function of the physico-chemical forms of radionuclides found in the environment was a problem encountered in many countries in assessing the consequences of the Chernobyl accident, the IAEA should promote the establishment of agreed values — initially for the most relevant radionuclides.
- (2) On the basis of experience gained from the Chernobyl accident, the IAEA should, in collaboration with organizations such as WHO and FAO, develop additional guidance on intervention dose levels and corresponding derived intervention levels appropriate to reducing the stochastic risk and collective

This publication has been superseded by INSAG-7

- dose equivalent commitment, especially at distances beyond the immediate area of accident impact.
- (3) The IAEA should develop technical guidance on criteria and procedures for radiological sampling and monitoring under emergency conditions, where the time and accuracy requirements, the radiation environment and the decision making needs differ from those associated with routine radiological sampling and monitoring.
 - (4) The IAEA should develop technical guidance for the rapid reporting, compiling and collating of large quantities of data after a nuclear accident (including environmental contamination data and meteorological data) to be used as input for radiological assessments.
 - (5) The IAEA should develop criteria for re-entry into facilities affected by nuclear accidents and into off-site areas and guidelines for recovery operations.
 - (6) The IAEA should develop, in the light of the Chernobyl accident, technical guidance (criteria and specifications) for clothing which will protect against very high levels of airborne beta contamination.
 - (7) The IAEA should develop technical guidance on assessments of the large scale contamination of people (external and internal contamination), equipment, facilities, premises, ground, water and air after a nuclear accident with a view to determining the scale of decontamination operations needed, and on radiation protection of the personnel carrying out such assessments.
 - (8) The IAEA should develop technical guidance on radiation protection aspects of the decontamination of a nuclear power plant and large areas of surrounding land after a nuclear accident.
 - (9) The IAEA should formulate practical guidance for responding to releases of radioactive material into the national environment which originate outside national boundaries but nevertheless require measures to be taken for the protection of the public.
 - (10) The IAEA should develop technical guidance on the use of real-time models able to accept actual meteorological and radiological monitoring system data in predicting the radiological consequences of a nuclear accident for persons and the environment and in determining what protective measures are necessary.
 - (11) In order to improve predictions of the consequences of accidental releases of radioactivity, the IAEA should, in collaboration with WMO, review and inter-calibrate models of atmospheric transport of radionuclides over short and long distances and of radionuclide deposition on terrestrial surfaces (soils, vegetation, buildings, etc.) and establish a database for validation studies on such models. In addition, it should carry out similar activities with regard to models of the transfer of radionuclides through the terrestrial environment and in food-chains, their transfer through surface waters (fresh water and sea water) and their transfer in urban environments.

This publication has been superseded by INSAG-7

- (12) The IAEA should promote an exchange of information on computer codes available or being developed for the probabilistic assessment of accident consequences.
- (13) It is very important to enable physicians, such as specialists in various fields and general practitioners, to give appropriate advice to members of the public concerning health consequences of accidental radiation exposure of various magnitudes and in various conditions. It appears an equally valid requirement that physicians who may be engaged in medical first aid and early treatment of accidentally exposed persons should possess adequate education and training. Therefore the IAEA should initiate, in collaboration with WHO, a study of which subjects should be introduced, and to what extent, into the basic and postgraduate training of physicians to assure fulfilment of these specified requirements.

C. GENERAL

Under the IAEA expanded programme in nuclear safety there are actions intended to help nuclear plant operators to maintain the highest possible safety level, with priority given to prevention of accidents.

These actions are already under way in the Agency programme, but could be significantly expanded with a clear safety benefit for the international community.

In particular, provision should be made for the IAEA to provide special assistance on request, particularly in support of countries with limited resources.

This publication has been superseded by INSAG-7

Annex

**RBMK REACTORS AT CHERNOBYL NUCLEAR POWER
STATION UNITS 3 AND 4**

This annex describes only those elements which are necessary to understand the operation of RBMK 1000 reactors and the accident at Unit 4 of the Chernobyl nuclear power station. Subsection 1 deals with the operating history of RBMK 1000 reactors, Subsection 2 with the reactor design, and Subsection 3 with the safety systems.

1. OPERATING HISTORY OF RBMK 1000 REACTORS

The history of RBMK type reactors in the Soviet Union has been very successful. After the early development of the system, the Soviet Union went directly to full scale 1000 MW(e) units. The first RBMK 1000 was put into service at Leningrad in 1974. The Leningrad, Kursk and Chernobyl power stations each have four units built in pairs, each unit supplying two 500 MW(e) turbogenerators. The first two (of four) units are operating at Smolensk and two more are being constructed at Chernobyl.

The first of two larger, 1500 MW(e), versions of these reactors was put into service at Ignalino in 1984. Its physical size is similar to that of the RBMK 1000 but it has a fuel power density 50% higher. The main technical parameters are given in Table III for both series of reactors.

In safety terms there has been practical demonstration that the design can handle significant faults. For example, at Kursk nuclear power station in January 1980, a total loss of station internal load occurred that was sustained satisfactorily, and there have been a number of feedwater system transients. None of these presented severe plant safety problems.

Table IV illustrates some of the performance data for these reactors.

**2. GENERAL DESCRIPTION OF THE CHERNOBYL STATION SITE
AND OF THE DESIGN FEATURES OF RBMK 1000 REACTORS**

2.1. Overview of the Chernobyl reactor site and plant layout

The Chernobyl nuclear power station (Fig. 5) is situated in the eastern part of a large region known as the Byelorussian-Ukrainian Woodlands, beside the River Pripjat, which flows into the Dnieper.

TABLE III. THE MAIN TECHNICAL CHARACTERISTICS OF NUCLEAR POWER PLANTS WITH RBMK TYPE REACTORS

Characteristics	RBMK 1000	BMK 1500
Electrical power (MW)	1000	1500
Thermal power (MW)	3200	4800
Steam output (t/h)	5800	8800
Steam parameters before turbines:		
Pressure (kgf/cm ²)	65	65
Temperature (°C)	280	280

TABLE IV. PERFORMANCE DATA FOR RBMK TYPE REACTORS

Performance data	Leningrad NPP	Kursk NPP	Chernobyl NPP	Smolensk NPP
Station capacity as of 1 Jan.1986 (MW)	4000	4000	4000	4000
Electricity production for the period 1981-1985 (10 ⁹ kW·h)	140.4	82.4	106.6	23.4
Station capacity factor for 1985 (%)	84	79	83	76
Unit capacity factor during 1985 (%)	91 (U4) 87 (U1)		90 (U2)	

Construction of the Chernobyl nuclear power station is being carried out in three stages with each stage comprising two RBMK 1000 units. The first stage (Units 1 and 2) was constructed between 1970 and 1977 and the second stage (Units 3 and 4) was completed in late 1983. In 1981 work was begun on the construction of two more units using the same reactors at a site 1.5 km to the south-east of the existing site.

Each two-unit stage has a common special water purification system and auxiliary facilities.

To the south-east of the site and directly within the Pripjat valley, a pond 22 km² in area was constructed to provide cooling water for the turbine condensers and the other heat exchangers of the first four units.

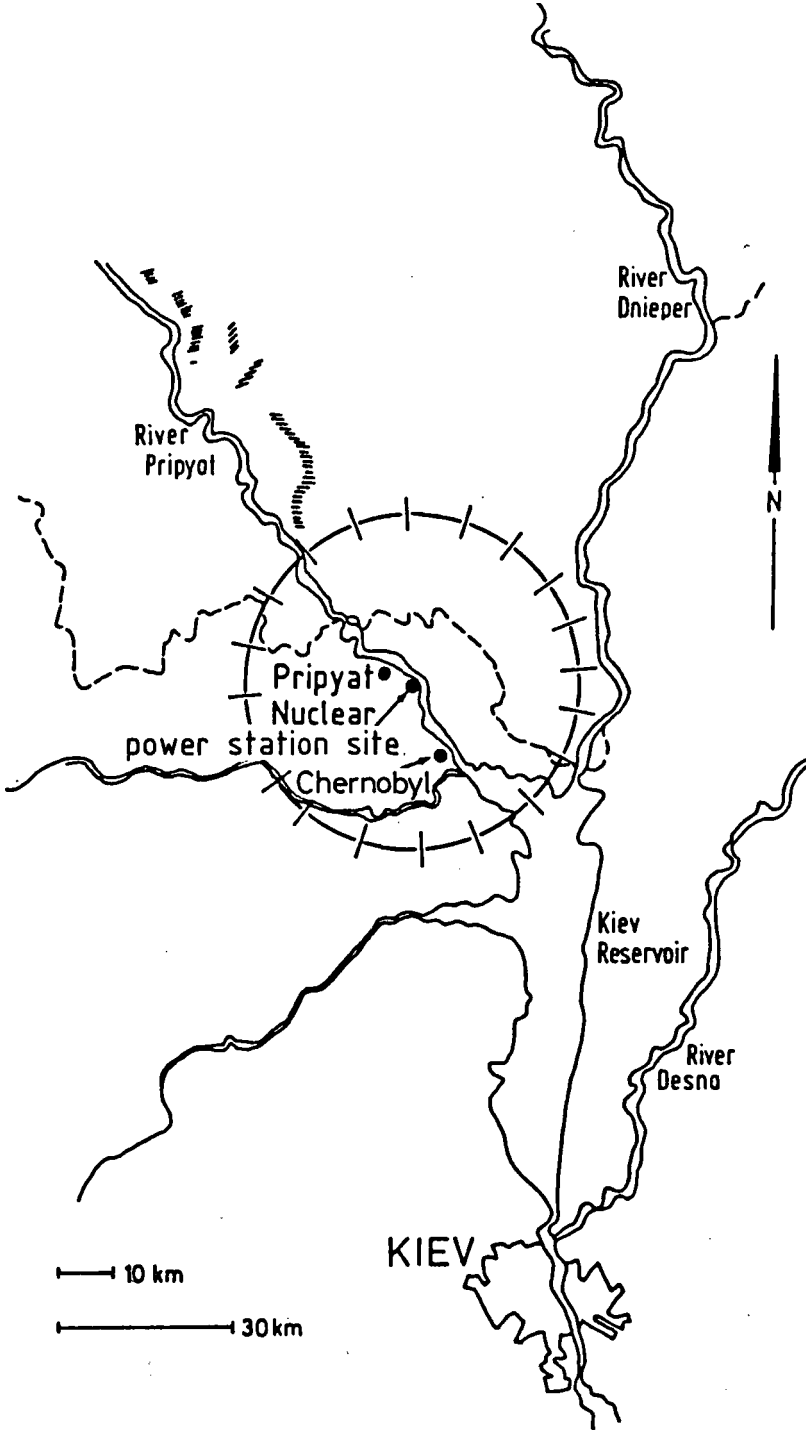

FIG. 5. The Chernobyl nuclear power station site.

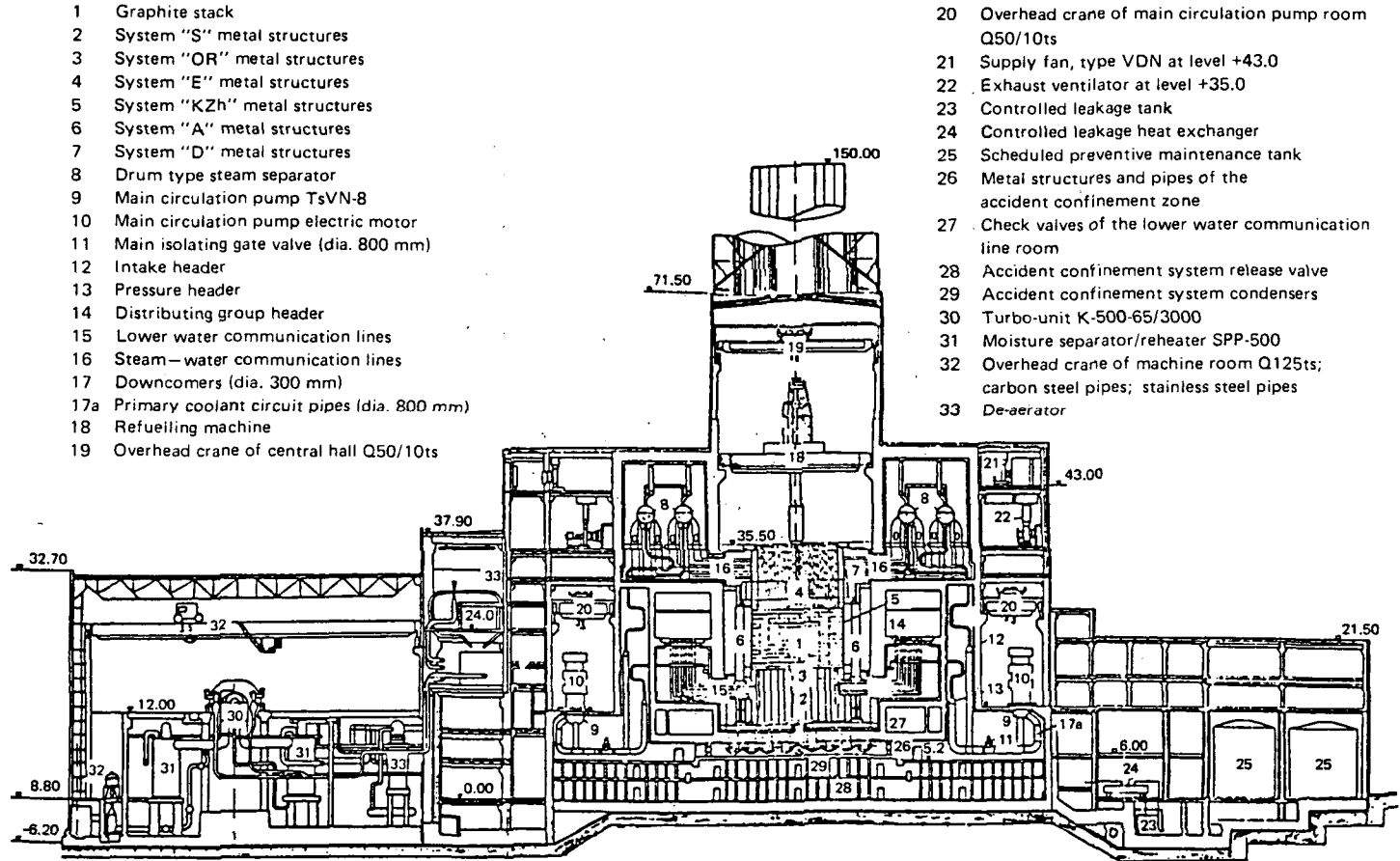

FIG. 6. Vertical section showing the principal installations in the main block of Chernobyl Unit 4. Dimensions are in metres.

This publication has been superseded by INSAG-7

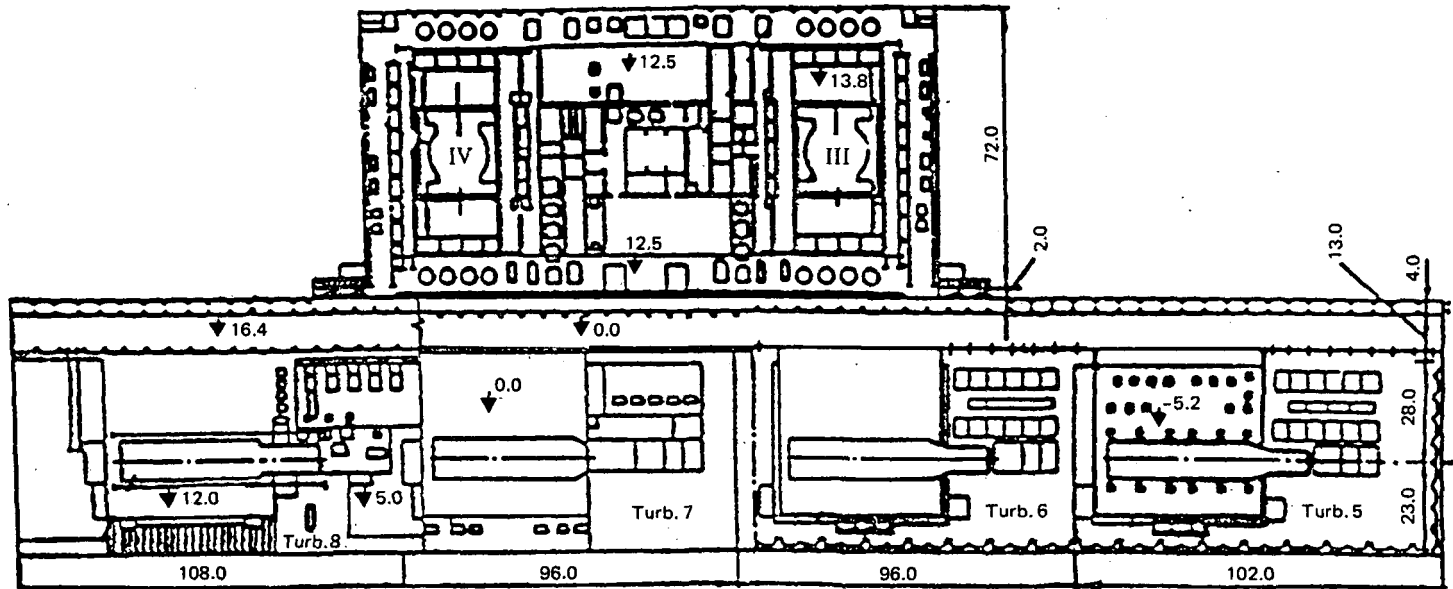

FIG. 7. Plan of the main building of Chernobyl Units 3 and 4. Dimensions are in metres.

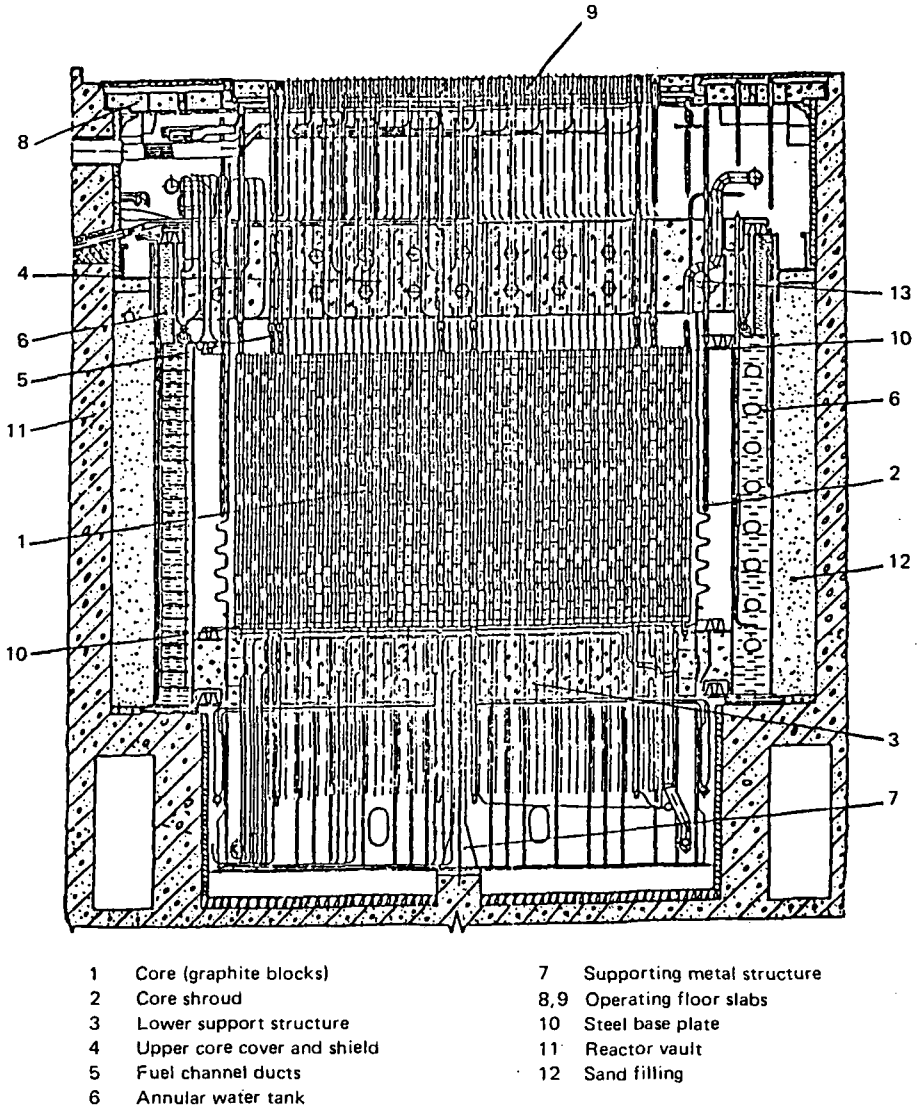

FIG. 8. The arrangement of the core of Chernobyl Unit 4.

A cross-sectional view of the main building of the Chernobyl reactor is shown in Fig. 6.

A schematic view of a two-unit stage is shown in Fig. 7. Each reactor unit supplies steam to two 500 MW(e) turbines.

The two reactors, together with their multiple forced circulation circuits, are located in separate blocks, between which are installed auxiliary systems.

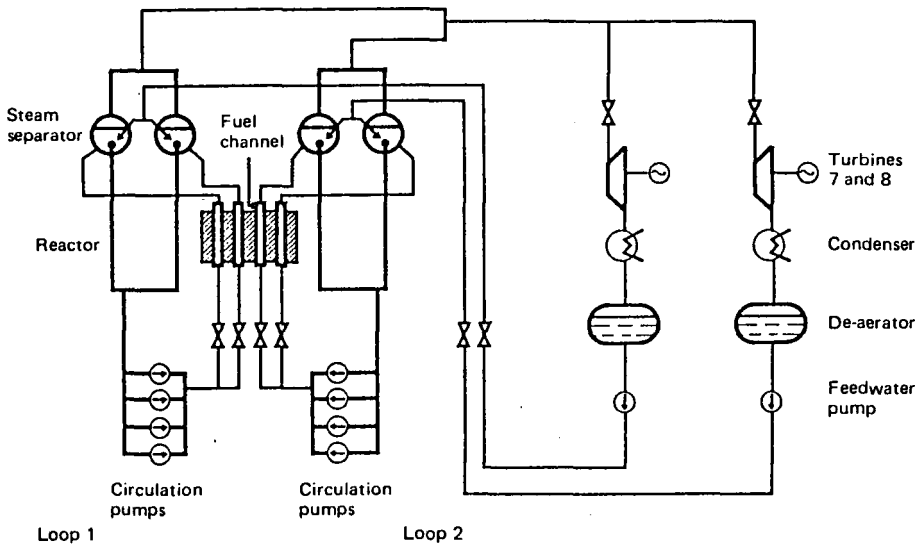

FIG. 9. Schematic diagram of the main water and steam circuits of Chernobyl Unit 4.

The turbine/generator (TG) room is common to two reactor units. It houses four turbogenerators and associated systems.

2.2. Overview of the features of RBMK 1000 reactors

The Chernobyl reactor is a graphite moderated, light water cooled system with the UO_2 fuel in 1661 individual vertical channels. The geometrical arrangement of the core can be seen in Fig. 8. It consists of graphite blocks (250 mm \times 250 mm, 600 mm high) stacked together to form a cylindrical configuration 12 m in diameter and 7 m high.

It is located in a leaktight cavity formed by a cylindrical shroud, the bottom support structure and the upper steel cover. Apart from the graphite blocks forming the radial reflector, each block has a central hole which provides the space for the fuel channels or one of the absorber rod channels, thus forming a lattice pitch of 250 mm.

Fuel and control rod channels penetrate the lower and upper steel structures and connect to two separate cooling systems below and above the core. The drives of the control rods are located above the core below the operating floor shield structure.

The fuel, in the form of UO_2 pellets, is sheathed with a zirconium-niobium alloy. Eighteen fuel pins approximately 3.5 m in length are arranged in a cylindrical cluster of which two fit on top of each other into each fuel channel. Fuel replacement

This publication has been superseded by INSAG-7

is done on-power by a fuelling machine located above the core. One to two fuel channels can be refuelled each day.

As schematically indicated in Fig. 9, the coolant system consists of two loops. The coolant enters the fuel channels from the bottom at a temperature of 270°C, heats up along its upward passage and partially evaporates. The mass steam content at the core outlet is approximately 14.5% at full power operation. The outlet pressure and corresponding temperature is 7 MPa (70 bars) and 284°C. The wet steam of each channel is fed to steam drums. There are two steam drums for each cooling loop. The separated dry steam (moisture content less than 0.1%) is supplied via two steam pipes to two turbines with an output of 500 MW(e) each, while the water, after mixing with the turbine condensate, is fed through 12 downcomers to the headers of the main circulation pumps. The condensate from the turbines enters the separators as feedwater, thereby subcooling the water at the main circulation pump inlet.

The circulation pumps supply the coolant to headers which distribute it to the individual fuel channels of the core.

The coolant flow of each fuel channel can be independently regulated by an individual valve in order to compensate for variations in the power distribution. The flow rate through the core is controlled by circulation pumps. In each loop four pumps are provided of which one is normally on standby during full power operation.

From the fission reaction approximately 95% of the energy is transferred directly to the coolant; 5% is absorbed within the graphite moderator and mostly transferred to the coolant. The latter part of the fission energy is transferred to the coolant channels by conduction leading to a maximum temperature within the graphite of approximately 700°C. A gas mixture of helium and nitrogen enhances the gap conductance between the graphite blocks and provides chemical control of the graphite and pressure tubes.

2.2.1. Control and protection system (CPS)

The control and protection system in the RBMK reactors has the following basic functions:

- (a) Regulation of the reactor power and reactor period in the range of 8×10^{-12} to 1.2 times full power;
- (b) Manual regulation of the power distribution to compensate for changes in reactivity due to burnup and other effects;
- (c) Automatic stabilization of the radial-azimuthal power distribution;
- (d) Controlled power reduction to safe levels when certain plant parameters exceed preset limits;
- (e) Emergency shutdown under accident conditions.

This publication has been superseded by INSAG-7

The system includes the following measuring devices:

- (a) Twenty-four ionization chambers placed in the reflector region which are used to drive three banks of automatic regulation rods;
- (b) Twenty-four fission chambers which are in-core detectors located in the central openings of fuel assemblies which are used to drive the local automatic controllers.

2.2.2. Reactivity control devices

There are 211 absorbing rods located in the core as shown in Fig. 10. These are functionally grouped as follows:

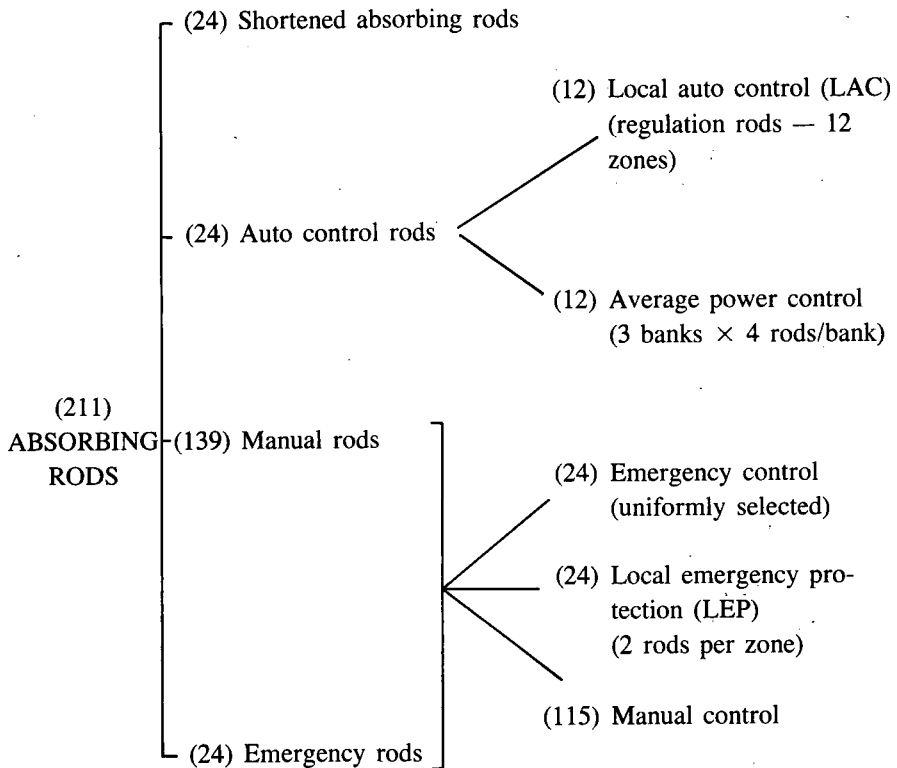

Main subsystems

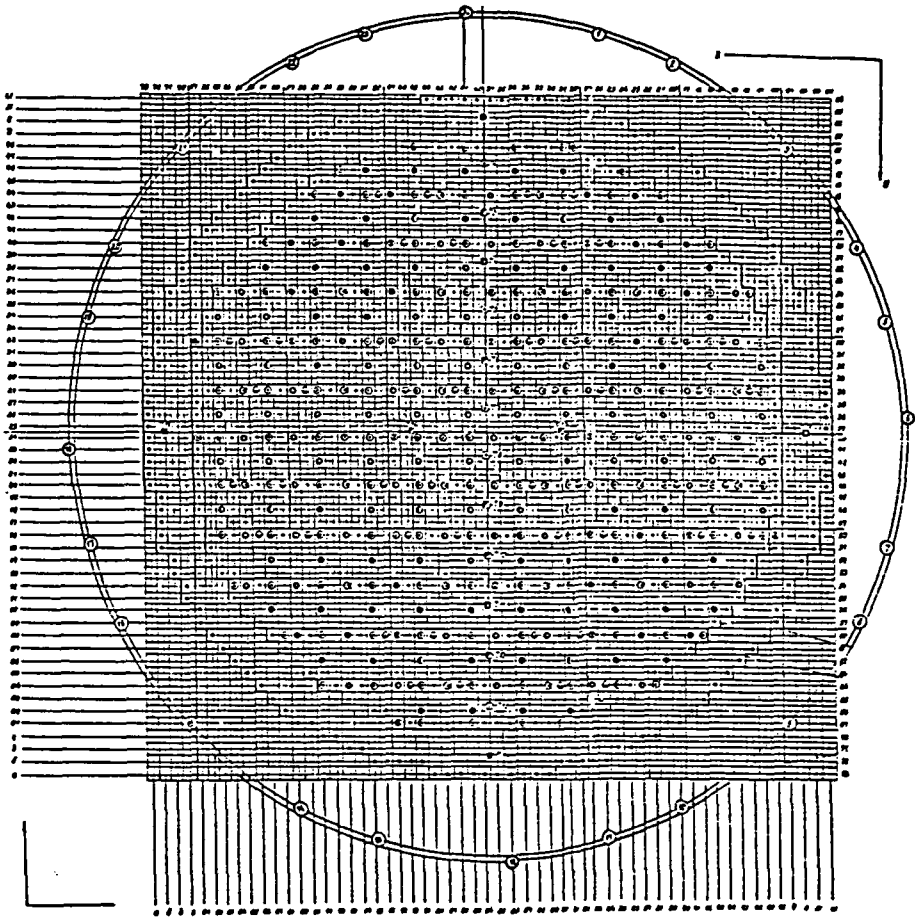

FIG. 10. Horizontal section of the core of the Chernobyl Unit 4 reactor showing the positions of the control rods.

- (a) Neutron flux monitoring. Fission chambers monitor neutron flux in startup regime and at intermediate power levels up to nominal power. Their signals are processed and used in the protection system and displayed in the main control room.
- (b) Automatic regulation of the reactor power. The system comprises three identical banks of automatic regulators of the average reactor power. The automatic regulating signal is generated by summing the relative deviations of the power for the required level from three out of four ionization chamber measurement channels. The system covers the low power range (0.5%–10% of full power) (one bank) and high power range (two banks).

This publication has been superseded by INSAG-7

Stabilization of the power density distribution is achieved by the local automatic regulators (LAR) and local emergency protection systems. The LAR is designed on the basis of independent power regulation in 12 local zones of the reactor core by means of 12 regulating rods.

The average power automatic regulating system is used for standby in the power range from 20–100%, and is switched on automatically when the LAR malfunctions.

The spatial power distribution is controlled by withdrawing the manual and automatic control rods upwards and the shortened control rods downwards.

The automatic regulators give a power holding accuracy for the reactor no worse than $\pm 1\%$ in relation to the required level in the range of 20–100% of full power and no worse than $\pm 3\%$ in the range of 3.5–20% of full power.

- (c) Emergency protection of the reactor. Reactor protection in the event of an emergency is achieved by automatic insertion of all absorber rods (except for the shortened rods).

Twenty-four rods uniformly distributed through the reactor are selected for the emergency protection mode from the total number of rods by a special selector circuit. When the reactor is started up, the twenty-four emergency protection rods are the first to be raised to the upper cutoff switches.

The speed of the control rods is 0.4 m/s. When the control rod is disconnected from its drive, which is necessary in the case of a power loss, the speed is about 0.4 m/s, driven by free fall. Flow resistance precludes a higher velocity.

The highest level of emergency is Level 5, which results in insertion of all the rods (except the shortened absorber rods) into the core up to the lower cutoff switches. The parameters used to initiate a Level 5 power reduction comprise neutronic related signals such as high power and short reactor period and a series of process related signals such as high and low level in the steam drums, high steam drum pressure, trip of two turbogenerators, etc. The over-power trip setpoint is set at present power plus 10% of nominal power.

2.2.3. Reactor process monitoring system

The reactor process monitoring system provides the operator with information in visual and documentary form on the values of the parameters which define the reactor's operating regime and the condition of its structural elements: the fuel channels, the control channels, reflector cooling, graphite stack, metal structure and so on.

This publication has been superseded by INSAG-7

The system includes the following measurements and subsystems:

- Flow rates in all the fuel channels and the control channels (1661 plus 223 points);
- The temperatures of the graphite core and metal structures (46 plus 381 points);
- A system for monitoring the main components of the forced circulation system, such as the drum separators, the main circulation pumps and the suction and pressure headers;
- A system for monitoring the power distribution (130 (radial) plus 84 (axial)).

The 'Skala' computerized central monitoring system is designed to carry out monitoring of the processes in the basic equipment of RBMK 1000 nuclear power station units, and to provide the operating staff with calculations and logic analysis of the process conditions of the units.

3. SAFETY SYSTEMS

3.1. Emergency core cooling system (ECCS)

The purpose of this system, schematically illustrated in Fig. 11, is to ensure the effective short and long term removal of decay and stored energy following an interruption of the normal cooling mode. The basic features are as follows:

- (1) Because the rupture can occur only in one of the two main circuits, the protection system has the capability to identify the ruptured and intact circuits.
- (2) To ensure a fast water injection into the broken circuit, pressurized water tanks are connected to this circuit (see Fig. 11), by opening a fast acting valve. These tanks are pressurized to 10 MPa (100 bar). The medium and long term water injection is ensured by feeding water with electrical drive pumps from the suppression pool into the broken circuit.

The pumping system consists of three pumping circuits, each with 50% capacity of the required amount of water and consisting of a high pressure and a low pressure pump. For long term operation the water in the suppression pool is cooled by means of heat exchangers.

- (3) The water supply to the intact circuit is ensured by three parallel electrically driven pumps delivering water from a tank containing clean condensate. Each pump delivers not less than 50% of the required mass flow.

3.2. Containment

The RBMK 1000 Stage II reactors (such as Chernobyl Units 3 and 4) have a containment with a suppression pool below the reactor. The major part of the con-

This publication has been superseded by INSAG-7

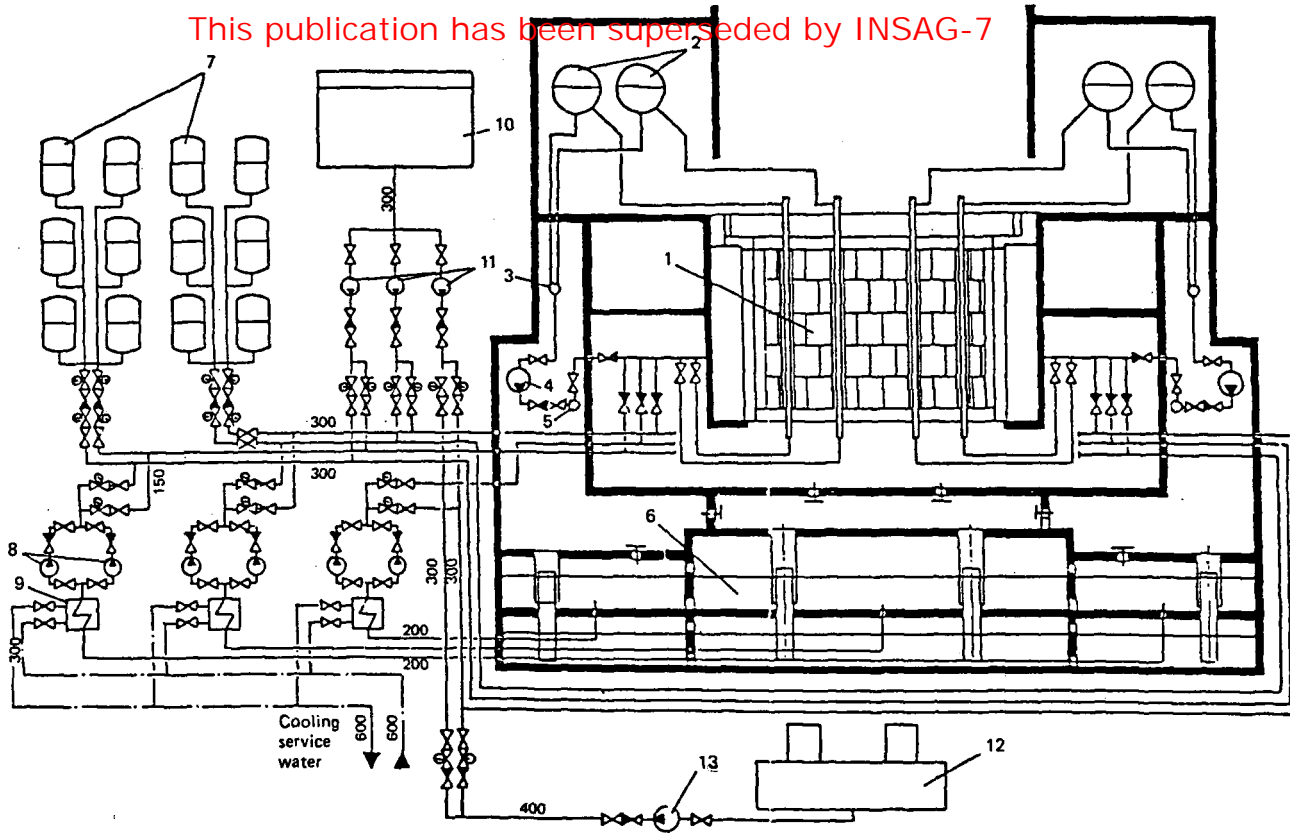

FIG. 11. Schematic diagram of the emergency core cooling system (ECCS) of Chernobyl Unit 4. Key: 1: reactor; 2: steam separators; 3: suction header; 4: main circulation pump; 5: pressure header; 6: pressure suppression pool; 7: ECCS vessels; 8: ECCS pumps for cooling the damaged half of the reactor; 9: heat exchangers; 10: clean condensate container; 11: ECCS pumps for cooling the undamaged half of the reactor; 12: de-aerator; 13: feed pump.

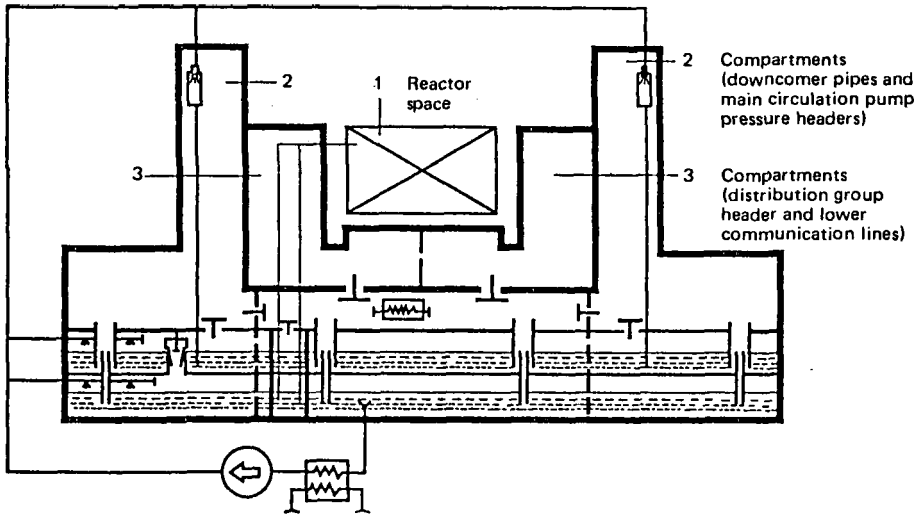

FIG. 12. Schematic diagram of part of the containment system (the 'accident localization system').

tainment is shown schematically in Fig. 12. This is termed the 'accident localization system' in the Soviet Working Documents.

The containment is structured in different compartments with different design overpressures. All compartments with pipes or vessels from the primary circuit are under a slight underpressure.

The main features are:

- (1) In the event of a rupture in the reactor space ((1) in Fig. 12) the steam, water, nitrogen, helium and possibly hydrogen are released through two pipes into the suppression pool, where the steam is condensed. The design overpressure of the reactor space is 0.08 MPa (0.8 bar).
- (2) Compartments (2) (in Fig. 12) contain the downcomer pipes and the main circulation pump pressure headers (average diameter 900 mm) and are designed for an overpressure of 0.45 MPa (4.5 bar).
- (3) Compartments (3) (in Fig. 12) contain the distribution group header and the lower communication lines and are designed for an overpressure of 0.08 MPa (0.8 bar).

The reactor space and the compartments (2) and (3) (in Fig. 12) are leaktight and serve also for leak detection.

The compartments are connected to the steam distribution and the water or gas space of the suppression pool by non-return or release valves, which commonly open at overpressure of 0.002 MPa (0.02 bar).

This publication has been superseded by INSAG-7

All pipes of the primary circuit penetrating a compartment boundary or the reactor space have an isolation valve, with the exception of the pipes of the primary circuit from the outlet of the core to the inlet of the steam separators. In the event of a break in this section the steam produced can be collected and partly condensed by the installed ventilation systems.

3.3. Main coolant circuit depressurization system

The RBMK 1000 reactors are equipped with a depressurization system to prevent excessive overpressure of the primary circuit. This system has main safety valves with a total capacity of 100% of the design steam flow. The steam is condensed in the suppression pool. The safety valves open at different pressures.

3.4. Other relevant safety systems

The reactor is also equipped with:

- A control channel cooling circuit;
- Gas circuits for the atmosphere in the reactor space for changing the nitrogen/helium ratio, condensing leaked steam and purification of oxygen, hydrogen, ammonia, steam, carbon monoxide, carbon dioxide, methane and nitrogen impurities;
- A redundant cooling and purification system for the spent fuel pool cooling water;
- A cooling system for the biological shield tanks.

This publication has been superseded by INSAG-7

LIST OF PARTICIPANTS

International Nuclear Safety Advisory Group (INSAG)

Birkhofer, A.	Meneley, D.
Chung, K.T.	Nozawa, M.
Dai, C.	Rabold, H.
Edmondson, B.	Tanguy, P.
Kouts, H.J.C.	Veeraraghavan, N.
Lepecki, W.	Vuorinen, A.P., Chairman

Abagyan A.A., Associated Expert

Beninson, D., Associated Expert

USSR Experts

Demin, V.F.	Roschin, V.D.
Il'in, L.A.	Ryzhov, M.N.
Kalugin, A.K.	Slesarev, I.S.
Lazutkin, E.S.	Zagorul'ko, V.M.
Pavlovskij, O.A.	

IAEA Experts

Boeri, G.C.	Comitato Nazionale per la Ricerca e per lo Sviluppo dell'Energia Nucleare e delle Energie Alternative (ENEA), Italy
Brown, A.	Ontario Hydro, Canada
Frescura, G.M.	Ontario Hydro, Canada
Hicken, E.F.	Gesellschaft für Reaktorsicherheit, Federal Republic of Germany
Hill, M.	National Radiological Protection Board, United Kingdom
Jeschki, W.	Nuclear Safety Division (ASK), Switzerland
Kress, T.	Oak Ridge National Laboratory, United States of America
L'Homme, A.	Institut de protection et de sûreté nucléaire (CEA), France
Liniecki, J.	Akademii Medyecznej w. Lodzi, Poland
Powers, D.	Sandia National Laboratories, United States of America
Young, J.D.	Central Electricity Generating Board, Berkeley Nuclear Laboratory, United Kingdom

IAEA Staff

Salo, A.	Yaremy, E.
Aleinikov, V.	Amano, F.
Bianco, A.	Byszewski, W.
Collins, H.	Fischer, J.
Emmerson, B.W.	Giuliani, P.
Flakus, F.N.	Gürpinar, A.
Inaba, J.	Jankowski, M.
Levin, I.	Joosten, J.
Utting, R.	Karbassioun, A.
	Kenneke, A.
	Tolstykh, V.D.

Lederman, L.

Delves, D., Editor

Iansiti, E., Scientific Secretary for INSAG

IAEA Secretariat

The following members of the IAEA Secretariat participated in some or all of the plenary sessions of the INSAG Meeting:

Blix, H.	Director General
Konstantinov, L.V.	Deputy Director General, Department of Nuclear Energy and Safety
Rosen, M.	Assistant Deputy Director General and Director, Division of Nuclear Safety
Wojcik, T.	Special Assistant to the Director General

This publication has been superseded by INSAG-7

HOW TO ORDER IAEA PUBLICATIONS

An exclusive sales agent for IAEA publications, to whom all orders and inquiries should be addressed, has been appointed in the following country:

UNITED STATES OF AMERICA Bernan Associates – UNIPUB, 10033-F King Highway, Lanham, MD 20706

In the following countries IAEA publications may be purchased from the sales agents or booksellers listed or through your major local booksellers. Payment can be made in local currency or with UNESCO coupons.

ARGENTINA	Comisión Nacional de Energía Atómica, Avenida del Libertador 8250, RA-1429 Buenos Aires
AUSTRALIA	Hunter Publications, 58 A Gipps Street, Collingwood, Victoria 3066
BELGIUM	Service Courrier UNESCO, 202, Avenue du Roi, B-1060 Brussels
CHILE	Comisión Chilena de Energía Nuclear, Venta de Publicaciones, Amunategui 95, Casilla 188-D, Santiago
CHINA	IAEA Publications in Chinese: China Nuclear Energy Industry Corporation, Translation Section, P.O. Box 2103, Beijing IAEA Publications other than in Chinese: China National Publications Import & Export Corporation, Deutsche Abteilung, P.O. Box 88, Beijing
CZECHOSLOVAKIA	S.N.T.L., Mikulandska 4, CS-116 86 Prague 1 Alfa, Publishers, Hurbanovo námestie 3, CS-815 89 Bratislava
FRANCE	Office International de Documentation et Librairie, 48, rue Gay-Lussac, F-75240 Paris Cedex 05
HUNGARY	Kultura, Hungarian Foreign Trading Company, P.O. Box 149, H-1389 Budapest 62
INDIA	Oxford Book and Stationery Co., 17, Park Street, Calcutta-700 016 Oxford Book and Stationery Co., Scindia House, New Delhi-110 001
ISRAEL	Heiliger and Co., Ltd, Scientific and Medical Books, 3, Nathan Strauss Street, Jerusalem 94227
ITALY	Libreria Scientifica, Dott. Lucio de Biasio "aeiou", Via Meravigli 16, I-20123 Milan
JAPAN	Maruzen Company, Ltd, P.O. Box 5050, 100-31 Tokyo International
NETHERLANDS	Martinus Nijhoff B.V., Booksellers, Lange Voorhout 9-11, P.O. Box 269, NL-2501 The Hague
PAKISTAN	Mirza Book Agency, 65, Shahrah Quaid-e-Azam, P.O. Box 729, Lahore 3
POLAND	Ars Polona-Ruch, Centrala Handlu Zagranicznego, Krakowskie Przedmiescie 7, PL-00-068 Warsaw
ROMANIA	Ilexim, P.O. Box 136-137, Bucharest
SOUTH AFRICA	Van Schaik Bookstore (Pty) Ltd, P.O. Box 724, Pretoria 0001
SPAIN	Díaz de Santos, Lagasca 95, E-28006 Madrid Díaz de Santos, Balmes 417, E-08022 Barcelona
SWEDEN	AB Fritzes Kungl. Hovbokhandel, Fredsgatan 2, P.O. Box 16356, S-103 27 Stockholm
UNITED KINGDOM	Her Majesty's Stationery Office, Publications Centre, Agency Section, 51 Nine Elms Lane, London SW8 5DR
USSR	Mezhdunarodnaya Kniga, Smolenskaya-Sennaya 32-34, Moscow G-200
YUGOSLAVIA	Jugoslovenska Knjiga, Terazije 27, P.O. Box 36, YU-11001 Belgrade

Orders from countries where sales agents have not yet been appointed and requests for information should be addressed directly to:



Division of Publications
International Atomic Energy Agency
Wagramerstrasse 5, P.O. Box 100, A-1400 Vienna, Austria

This publication has been superseded by INSAG-7

86-04501

This publication has been superseded by INSAG-7

FIG. 1. The time variation of reactor parameters in the simulation of the Chernobyl accident.

KEY TO THE CURVES ON FIG. 1

SYM	MIN	MAX	SYM	MIN	MAX
A Neutron power (%)	0	120	K Flow, MCP (m ³ /s)	2	8
B Reactivity, sum. (%)	-1	+5	L Flow, Feedwater (kg/s)	0	600
C Pressure, steam drum (bar)	54	90	M Flow, steam (kg/s)	0	600
D Neutron power (%)	0	48000	N Fuel temp. (°C)	200	2000
E Rod group AR-1 (fraction inserted)	0	1.2	O Steam mass quality (Exit of core, %)	0	6
G Rod group AR-2 (fraction inserted)	0	1.2	P Steam vol. quality (Core average, void fraction)	0	1.2
H Rod group AR-3 (fraction inserted)	0	1.2	S Level (steam drum, mm)	-1200	0

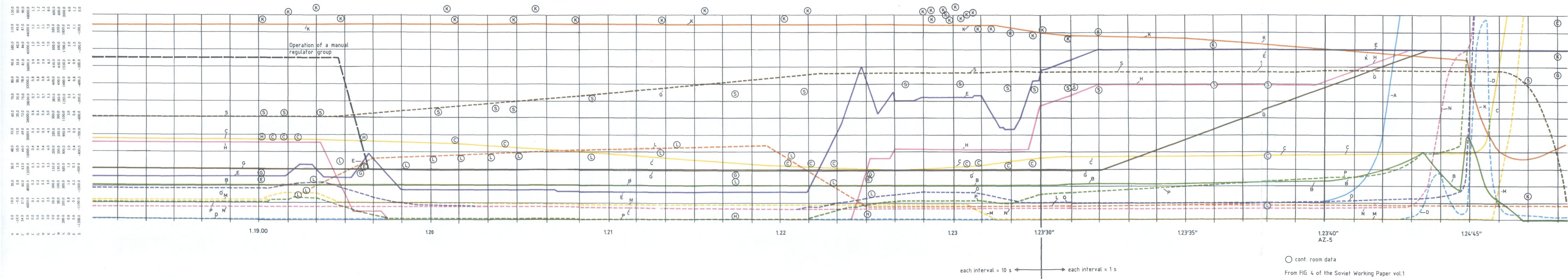

FIG. 1. [The time variation of reactor parameters in the simulation of the Chernobyl accident. Source: Fig. 4 of the Soviet Working Documents, Part I.

This publication has been superseded by INSAG-7

INTERNATIONAL
ATOMIC ENERGY AGENCY
VIENNA, 1986

SUBJECT GROUP: II
Nuclear Safety and Environmental Protection/Nuclear Safety
PRICE: Austrian Schillings 260,—